

bridges | connect  
share  
achieve



## INSTALLATION GUIDE

Effective March, 2013

# BRIDGES II INSTALLATION GUIDE

## Structure and Worksurfaces P.03

Beam Applications	03
Supporting Structure	04
Legs and Beams	04
Telescopic Beam	06
120° Leg	07
Storage Table Beam	08
Sliding Return	09
Round Table Supports	10
Glide Tray Adapter Assembly	10

## Power, Data and Cable Management P.11

Power Delivery/Cable Management	11
Wire Basket	12
Below Worksurface Power Trough	12
Below Worksurface Power Trough Installation	12
Power Trough 120° Installation	13
Power Trough Electric Components	14
Single Sided Power Trough	16
Above Worksurface Power Trough	17
Back-to-Back Storage Tower Gap Filler	18
34" Leg Shroud	19
Ceiling Feed	20
Power Distribution Storage	21

## Accessories P.22

Dividers	
Back-to-Back	22
Side-to-Side	23
Parallel with modesty panel	23
Perpendicular end of run	24
Modesty panel	25
Half Height Rectangular Leg Gable	26
Full Height Rectangular Leg Gable	27
Table Mounted Divider	28
Glass Perpendicular End of Run	29
Glass Side-to-Side	30

## Storage P.31

Shelves	
Elevated	31
Shared Storage	31
Table Mounted End Shelf	32
Storage Spine	34
Storage Cabinet Leg Assembly	35

## Bridges II

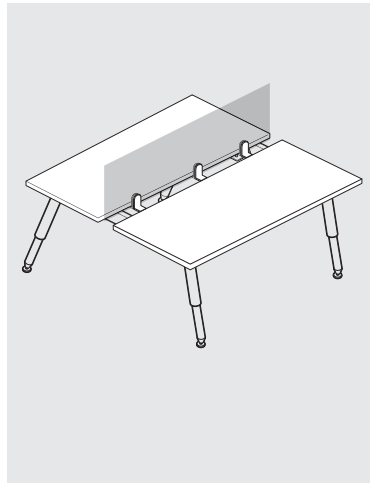

### Required Tools

Safety Glasses



Wrench



Allen Key

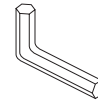

Flathead Screwdriver

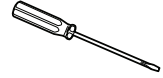

Phillips Screwdriver



## Bridges II Installation Sequence

NOTE: Although some illustrations depict round legs and some rectangular legs, the leg-to-beam and leg-to-worksurface assembly is the same.

### STEP 1: LAYOUT ORIENTATION

Orient the layout plan within the installation area, determine the location of table assemblies, power source and main storage components; establish the highest point on the floor.

### STEP 2: SUPPORTING STRUCTURE - legs, supporting beams

Identify type and size of required components and position them in accordance with layout plans. Proceed with connecting legs and structural beams (see the following pages for detailed instructions). Make sure that all rails are leveled and securely connected before proceeding with installation of worksurfaces.

### STEP 3: WORKSURFACES

### STEP 4: ACCESSORIES - task and paper organizers

Determine type and location of accessories as specified in floor plans. Proceed with installation of accessories.

### STEP 5: STORAGE

### STEP 6: ELECTRICS and DATA / COMMUNICATION - cable routing; cable management

Connect power feed harness to building power supply; check circuit assignments and functionality of power delivery at each duplex receptacle.

### STEP 7: WALK THROUGH / INSTALLATION INSPECTION

Please contact your Global CustomerCare Representative at 800-220-1900 for any questions or concerns.

NOTE: Any alterations to listed components will void the manufacturer's warranty. The manufacturer will not be responsible for any damage or bodily harm caused by alterations in accordance with national or local electrical codes and manufacturer's

specifications. In accordance with the manufacturer's policy of continual product improvement, the product presented in this document is subject to change without notice or obligation.

# BRIDGES II INSTALLATION GUIDE

## Structure and Worksurfaces P.03

Beam Applications	03
Supporting Structure	04
Legs and Beams	04
Telescopic Beam	06
120° Leg	07
Storage Table Beam	08
Sliding Return	09
Round Table Supports	10
Glide Tray Adapter Assembly	10

## Power, Data and Cable Management P.11

Power Delivery/Cable Management	11
Wire Basket	12
Below Worksurface Power Trough	12
Below Worksurface Power Trough Installation	12
Power Trough 120° Installation	13
Power Trough Electric Components	14
Single Sided Power Trough	16
Above Worksurface Power Trough	17
Back-to-Back Storage Tower Gap Filler	18
34" Leg Shroud	19
Ceiling Feed	20
Power Distribution Storage	21

## Accessories P.22

Dividers	
Back-to-Back	22
Side-to-Side	23
Parallel with modesty panel	23
Perpendicular end of run	24
Modesty panel	25
Half Height Rectangular Leg Gable	26
Full Height Rectangular Leg Gable	27
Table Mounted Divider	28
Glass Perpendicular End of Run	29
Glass Side-to-Side	30

## Storage P.31

Shelves	
Elevated	31
Shared Storage	31
Table Mounted End Shelf	32
Storage Spine	34
Storage Cabinet Leg Assembly	35

## Bridges II

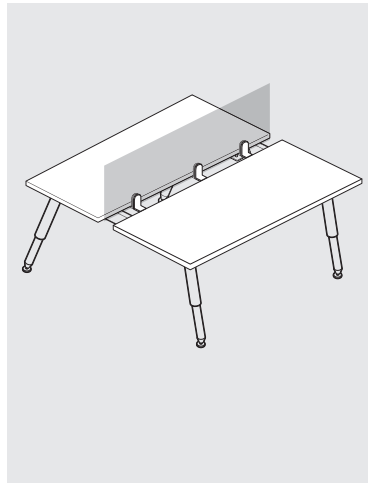

### Required Tools

Safety Glasses



Wrench



Allen Key



Flathead Screwdriver

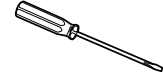

Phillips Screwdriver



## Bridges II Installation Sequence

NOTE: Although some illustrations depict round legs and some rectangular legs, the leg-to-beam and leg-to-worksurface assembly is the same.

### STEP 1: LAYOUT ORIENTATION

Orient the layout plan within the installation area, determine the location of table assemblies, power source and main storage components; establish the highest point on the floor.

### STEP 2: SUPPORTING STRUCTURE - legs, supporting beams

Identify type and size of required components and position them in accordance with layout plans. Proceed with connecting legs and structural beams (see the following pages for detailed instructions). Make sure that all rails are leveled and securely connected before proceeding with installation of worksurfaces.

### STEP 3: WORKSURFACES

### STEP 4: ACCESSORIES - task and paper organizers

Determine type and location of accessories as specified in floor plans. Proceed with installation of accessories.

### STEP 5: STORAGE

### STEP 6: ELECTRICS and DATA / COMMUNICATION - cable routing; cable management

Connect power feed harness to building power supply; check circuit assignments and functionality of power delivery at each duplex receptacle.

### STEP 7: WALK THROUGH / INSTALLATION INSPECTION

Please contact your Global CustomerCare Representative at 800-220-1900 for any questions or concerns.

NOTE: Any alterations to listed components will void the manufacturer's warranty. The manufacturer will not be responsible for any damage or bodily harm caused by alterations in accordance with national or local electrical codes and manufacturer's

specifications. In accordance with the manufacturer's policy of continual product improvement, the product presented in this document is subject to change without notice or obligation.

**Beam Applications**

Legs are connected with supporting beams. There is one beam for a single line of tables while two beams connect back-to-back table structures. Adjustable clamps at either end of the beam can be adjusted to accommodate the following applications in both single table as well as back-to-back table configurations.

**STANDARD TABLE BEAM**

**Single table beam application (1)**

Designed to bridge two legs to form support for a single table, or for two back-to-back worksurfaces. Adjustable clamps at either end of the beam are pushed all the way in to allow both table legs to be tucked under the worksurface.



**End of run table beam application (2)**

Supports one table leg assembly tucked under the worksurface (one adjustable clamp pushed all the way in), while the other table leg assembly can be shared between two adjacent worksurfaces (adjustable clamp pulled out to extend the beam).



**Interconnecting table beam application (3)**

Supports both table leg assemblies extended to support adjacent worksurfaces on either side. Adjustable clamps at either end of the beam are pushed all the way in to allow both table legs to be tucked under the worksurface. Single table beam application supports single table leg assemblies with legs on both sides tucked under the worksurface.

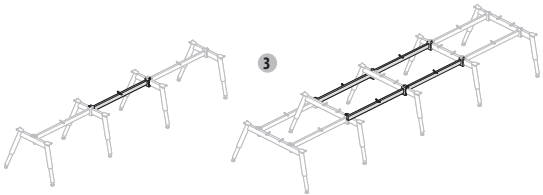

**TELESCOPIC TABLE BEAM (4)**

Supports a return connected perpendicularly to a 24" or 30" deep primary worksurface. The Telescopic beam is connected to a single or back-to-back leg on one side and to any worksurface supporting beam on the opposite side. Telescopic beam clamp allows the table leg to be tucked under the worksurface or shared between two adjacent worksurfaces.

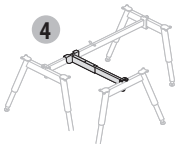

**STORAGE TABLE BEAM (5)**

The Storage beam is connected to a single or back-to-back leg on one side and to the worksurface on the opposite side - thus saving one leg assembly. Assembly worksurface is connected to storage units with included storage brackets. Storage table beam's flexibility allows for a single table application (with the table leg tucked in under the worksurface) as well as for a double table installation (two adjacent tables supported by a shared leg in the middle and two storage cabinets at the opposite ends).

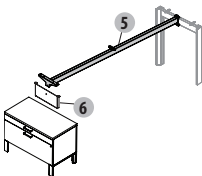

**STORAGE TABLE BEAM ADAPTER (6)**

Connects to a storage table beam. This assembly allows a worksurface to be supported by a leg on one side and a spine (formed by interconnected storage cabinets) on the opposite side.

# BRIDGES II INSTALLATION GUIDE

## Supporting Structure Round Leg Height Adjustment

Set the legs to desired height.

The inner leg has two threaded holes.

STEP 1: The top threaded hole is typically used to secure legs with levelers.

STEP 2: The lower threaded hole is used for securing legs with casters.

STEP 3: If the desired top surface height is 29" from the floor, for instance, and the table structure is to be on levelers, align top threaded hole in the inner leg (1) with the fourth hole in the table leg (3) as illustrated. When installing legs on casters, align the lower (2) threaded hole in the inner leg with the same fourth hole (3) in the table leg and secure with provided screws.

STEP 4: The height adjustment screws must be only used with the provided, translucent cup/washer.

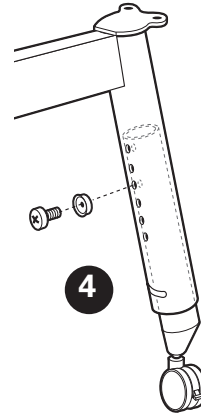
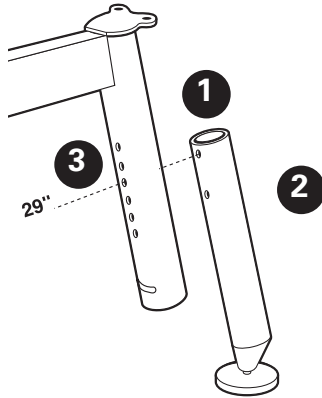

## Supporting Legs and Beams

Table legs are connected to the table supporting beams with die cast aluminum adjustable clamps. The position of these clamps on the beam establishes whether the leg is going to be shared between two adjacent worksurfaces (extended position) or tucked under a worksurface edge (retracted position).

STEP 1: Identify type and length of beam required. A single table, for instance will have both legs tucked under the worksurface and both end brackets, therefore, will be fully contracted. End of run table applications will require one of the beam brackets extended so that the leg it will be connected to could be shared between two adjacent worksurfaces (while the leg on the opposite end of the beam will be tucked under the worksurface at the end of a table run). Similarly, fully extending both beam brackets will allow both table legs to be shared.

STEP 2: In order to adjust beam bracket position, remove both countersunk Allen head screws from the beam clamp assembly. End of supporting beam tube can be seen through the gap between the two beam clamp parts (A). Lines on the bottom part identify two clamp positions. Slide the top part of the clamp along the beam into the desired position, enclose assembly with the bottom clamp part and tighten the countersunk Allen head screws.

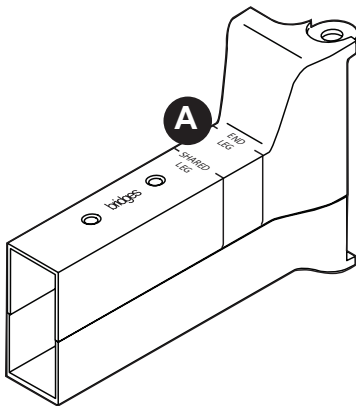
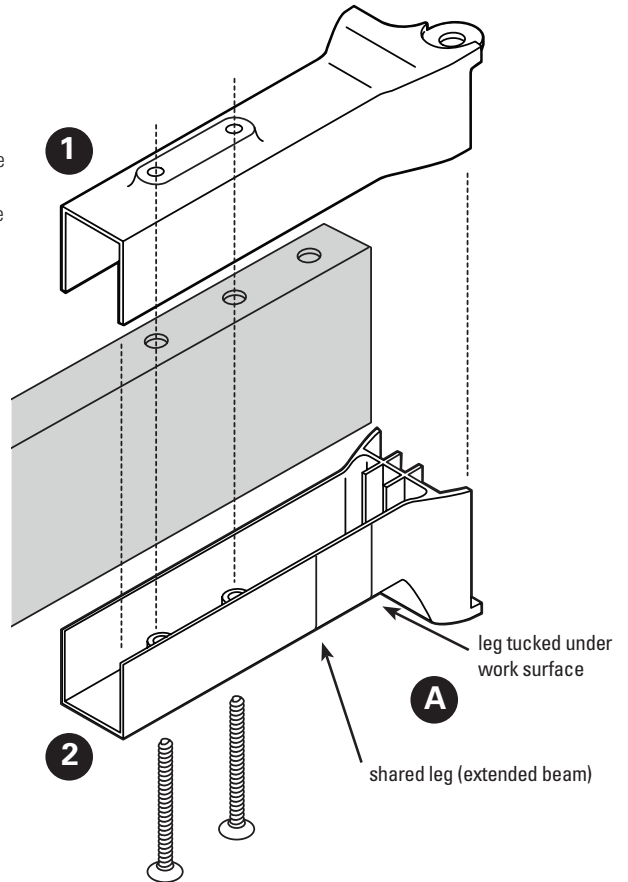

Supporting Legs and Beams (continued)

STEP 3: Position beam's end bracket over leg's horizontal, rectangular tube.

STEP 4: Secure top and bottom bracket ends with two supplied screws, but do not tighten the bottom screw.

Level the whole assembly.

STEP 5: Place worksurfaces on top of table structure, align them and interconnect them using flat brackets.

STEP 6: Align this worksurface assembly with legs and secure with screws. Proceed from one corner to the opposite one.

STEP 7: Ensure legs are vertical and tighten the bottom screw.

STEP 8: Adjust nylon set screws in the middle of the beam to flatten the worksurface (if required)

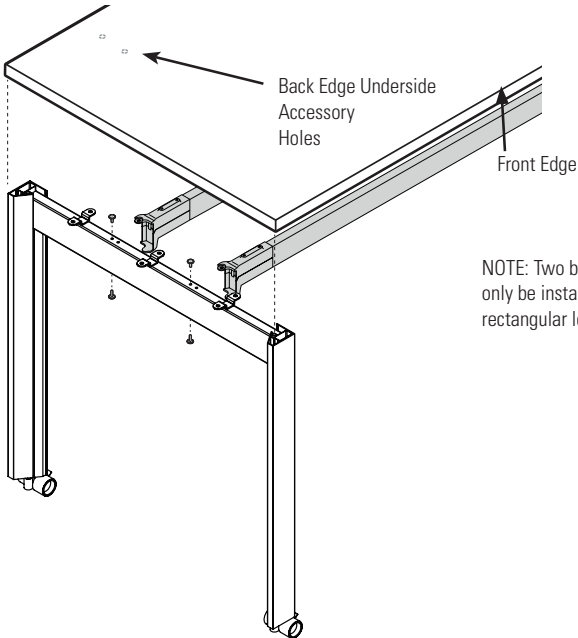
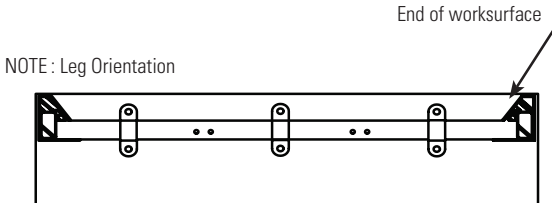
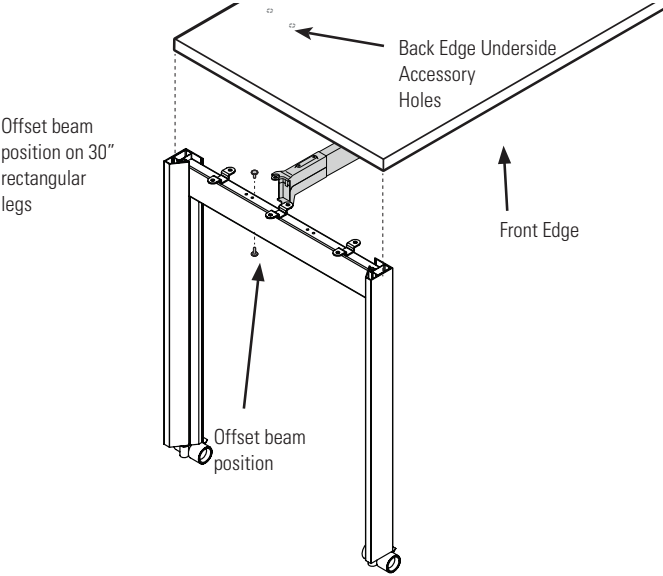
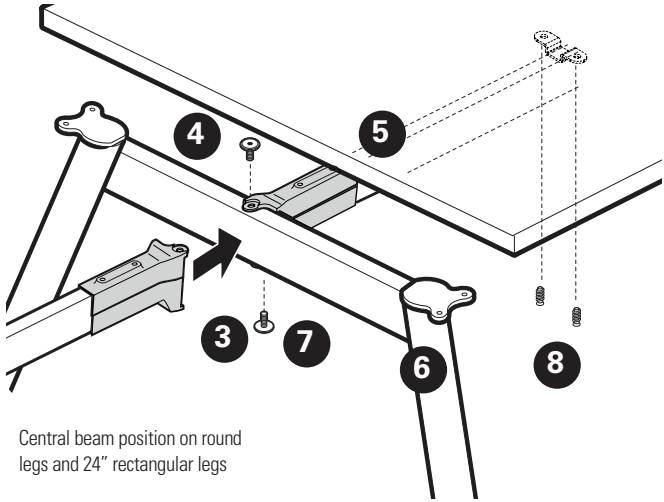

NOTE: Two beams can only be installed on 30" rectangular legs.

# BRIDGES II INSTALLATION GUIDE

## Telescopic Beam

Designed to provide support for worksurfaces perpendicularly connected to a primary table run. The telescopic beam is connected to the leg's horizontal, rectangular tube on one side, while the opposite side is secured off module to the perpendicular, central beam and can be adjusted to accommodate 24" and 30" deep primary worksurfaces.

STEP 1: Position beam's end bracket over leg's horizontal, rectangular tube.

STEP 2: Secure top and bottom bracket ends with two supplied screws.

STEP 3: Adjust the length of the telescopic beam in accordance with the depth of primary worksurface. Completely contracted beam will support perpendicular side table connected to 24" deep primary worksurface on Round and Rectangular legs. Middle position is intended to support perpendicular side table connected to 30" deep primary worksurface on Round legs. Fully extended telescopic beams support perpendicular side table connected to 30" deep primary worksurface on Rectangular legs.

STEP 4: Position end bracket of the telescopic beam over the primary, perpendicular beam. Level the whole assembly.

STEP 5: Install primary worksurface.

STEP 6: Secure the secondary worksurface to legs first.

STEP 7: Adjust the secondary worksurface/telescopic beam position.

STEP 8: Secure the worksurfaces with flat brackets.

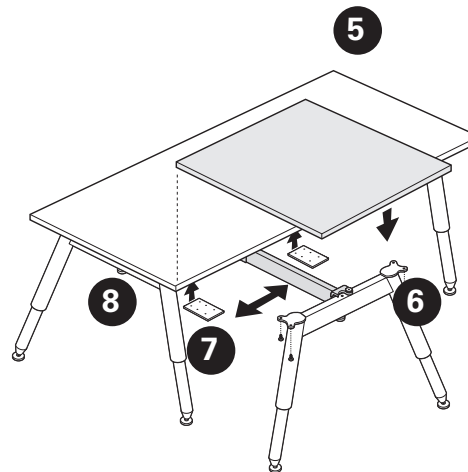
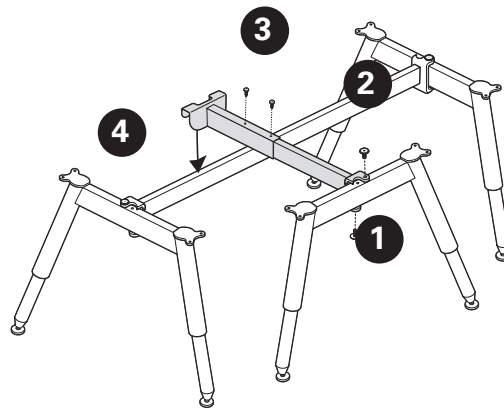

**120° Leg**

The integrated 120° beam bracket allows for the beam to be mounted in two positions:  
A) end of run leg placement  
B) shared leg placement

Identify the desired leg position (A or B)

- STEP 1: Align two mounting holes in beam with two holes in the integrated 120° beam bracket. Position beam's end bracket over leg's horizontal, rectangular tube.
- STEP 2: Secure both beams to the integrated 120° beam bracket with four supplied screws.
- STEP 3: Position beam's end bracket over leg's horizontal rectangular tube.
- STEP 4: Secure top and bottom bracket ends with two supplied screws.
- STEP 5: Level the whole assembly.
- STEP 6: Install worksurfaces and secure with supplied screws by proceeding from the central, 120° leg to the outside of the assembly in both directions.

NOTE: 24" deep worksurfaces are mounted centrally on top of the table structure. 30" deep worksurfaces are mounted off center, with a longer overhang facing the user.

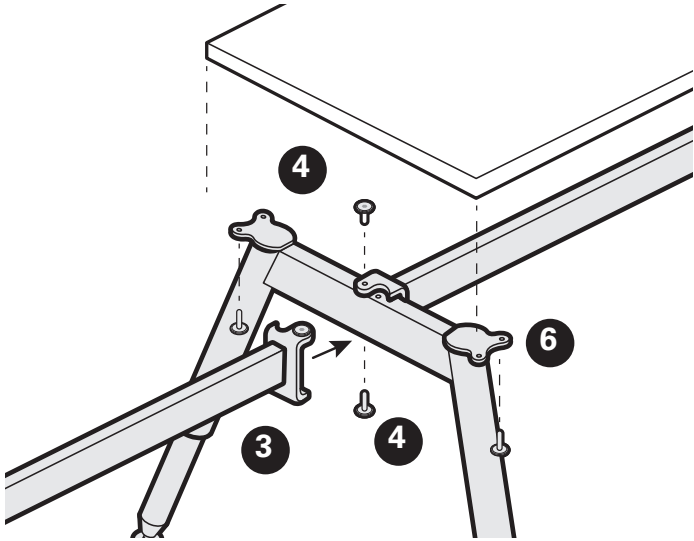
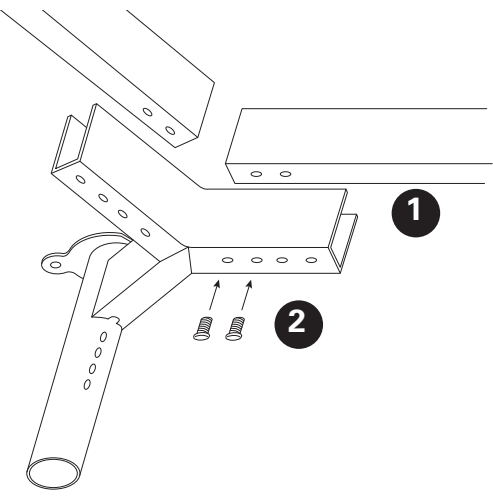
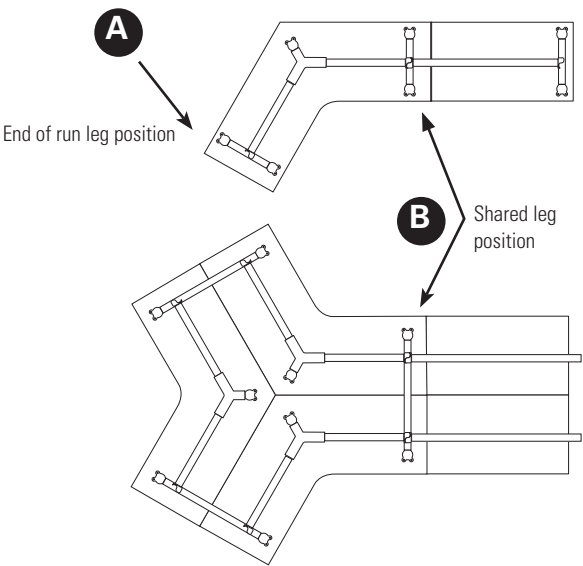



# BRIDGES II INSTALLATION GUIDE

## Storage Table Beam

Storage table beam's flexibility allows for a single table application (with the table leg tucked in under the worksurface) as well as for a double table installation (two adjacent tables supported by a shared leg in the middle (A) and two storage cabinets at the opposite ends).

- STEP 1: Position beam's end bracket over leg's horizontal, rectangular tube. Use Allen keys to secure top and bottom bracket ends with two supplied screws. Level the whole assembly.
- STEP 2: Turn the worksurface upside down on a smooth surface and secure it to the leg/beam subassembly with supplied screws.
- STEP 3: Mount two L brackets to the side of Storage tower. Drive two supplied machine screws through the brackets into threaded inserts embedded in the storage tower side panel.
- STEP 4: Place the Storage tower in its final location and position the leg/beam/worksurface assembly so that the worksurface rests on the installed L brackets. Ensure that the worksurface and the tower are aligned. Secure the worksurface to the L brackets with supplied screws.

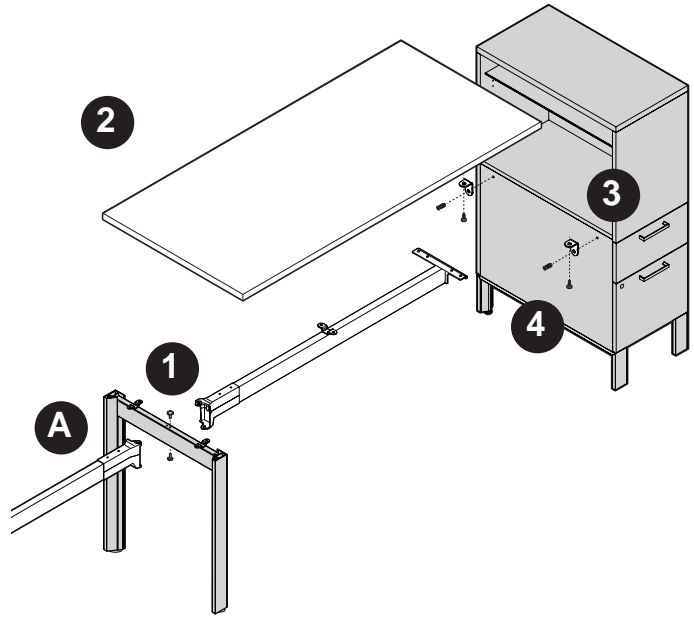

## Spine / Storage Table Beam Adapter

Storage table beam adapter allows a worksurface to be supported by a leg on one side and a spine storage cabinet on the opposite side. A typical Storage spine is formed by series of interconnected 21" or 25" high storage cabinets of corresponding depth.

The Storage beam is connected to a single or back-to-back leg on one side and to the worksurface on the opposite side - thus saving one leg assembly.

The 21" or 25" adapters provide structural support - acting as supports between top of the storage cabinet spine and the bottom of perpendicular worksurfaces.

The flexible leg/beam/adapter assembly arrangement allows the leg to be tucked in under the worksurface or to be shared by two adjacent worksurfaces. Included hardware connects the adapter to the worksurface and to the storage table beam.

- STEP 1: Position beam's end bracket over leg's horizontal, rectangular tube. Use Allen keys to secure top and bottom bracket ends with two supplied screws.
- STEP 2: Attach Spine / Storage table beam adapter to the Storage table beam. Use Allen key and the supplied screw to secure.
- STEP 3: Turn the worksurface upside down on a smooth surface and secure it to the leg/beam/adapter subassembly with supplied screws.
- STEP 4: Rest the leg/beam/adapter/worksurface assembly on top of the storage spine. Adjust the desired position. Secure the assembly by driving two supplied screws through the bottom of the adapter, into the top of the storage cabinet.

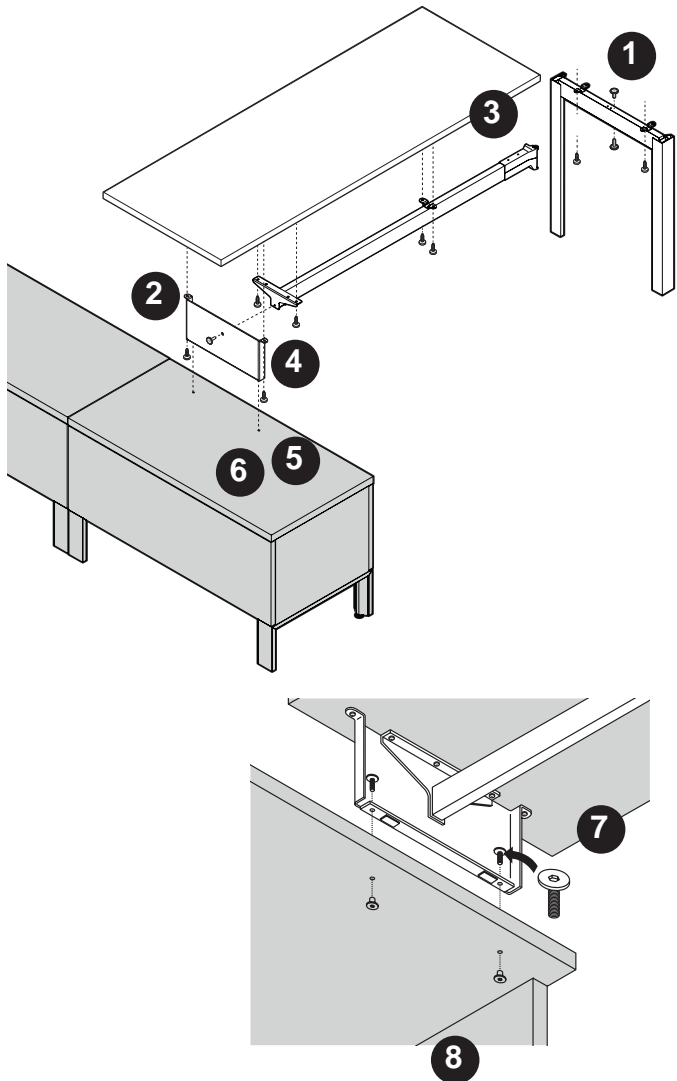

Sliding Return

NOTE:

Round legs:

Sliding Return can be installed anywhere along the front edge of worksurface supported by round legs.

Rectangular legs:

Sliding Return can be installed along the front edge of worksurface between Rectangular legs.

Sliding return can be installed under a seam of two adjacent worksurfaces supported by recessed, 3/4" back-to-back leg.

Ensure that back-to-back table installation is complete, level and structurally sound. Installation of Sliding Rail requires a special degree of accuracy of worksurface alignment. Failure to do so may result in binding of the sliding mechanism on the Sliding Rail.

Establish range of the Sliding Return.

- STEP 1: Mark a line 3" in from (and parallel with) the front edge of worksurface.
- STEP 2: Position the Sliding Rail and secure it with supplied screws. Always proceed from the second hole, leaving the first hole for installation of the Rail stop.

NOTE: The pair of screws provided to secure the rubber rail stops at either end of the rail are longer than the screws for securing the rail to the worksurface. Do not use these longer screws to secure the rail as the screws may penetrate through the top of the worksurface.

STEP 3: Secure leg support bracket to a leg frame with supplied machine screws (wide flat allen head).

STEP 4: Place the Sliding Return worksurface upside down on a clean surface. Secure the leg assembly to the worksurface with supplied wood screws. Ensure that the legs are set to the same height as the legs supporting the rest of the table installation.

STEP 5: Place eight supplied rubber spacers over pre-drilled holes. If you are converting an existing Return worksurface to a Sliding Return, mark a line 1" in from (and parallel with) the edge of the Return worksurface.

STEP 6: Align supporting brackets with rubber spacers / pre-drilled holes (or the marked line) and secure both brackets with supplied wood screws.

NOTE: In order to ensure a smooth sliding action, both brackets must be perfectly perpendicular to the edge of the return worksurface.

STEP 7: Slide the two glide blocks with bushings carefully onto the Rail as illustrated.

STEP 8: This step requires two people:  
 While the leg supported side of the Return rests on the floor have an assistant position supporting brackets under sliding glide blocks, align the holes and gently drive in two machine screws (metric M6 as provided). Do not tighten. In the same manner secure the second bracket to the second glide block and test smoothness of the slide. Carefully tighten all four metric screws while repeatedly testing smoothness of the slide. If the return binds on the Sliding Rail, then your support bracket(s) are not perpendicular to the rail - causing the glide blocks to jam.

STEP 9: Secure rail stops to both ends of the rail with supplied (longer) screws to prevent disengagement.

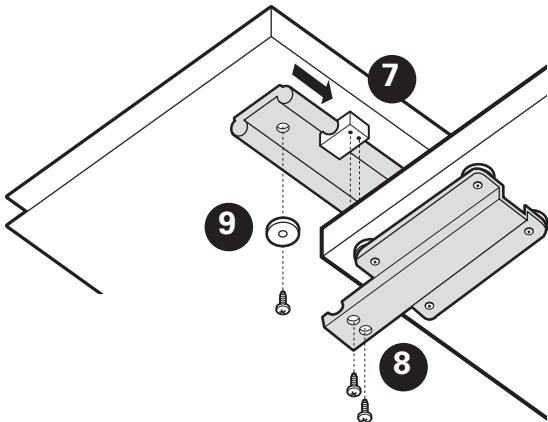
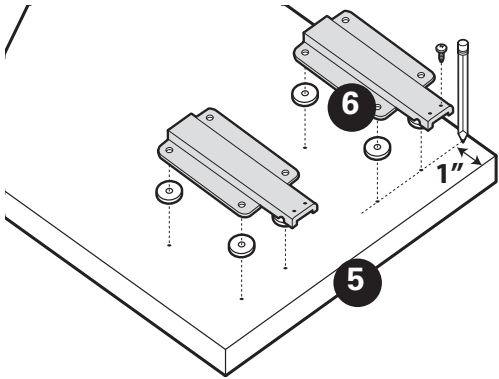
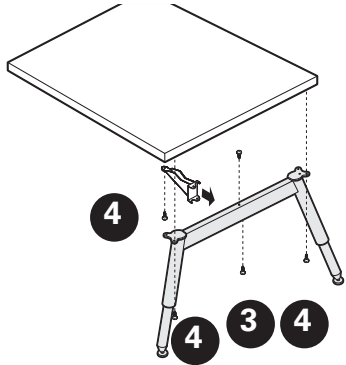
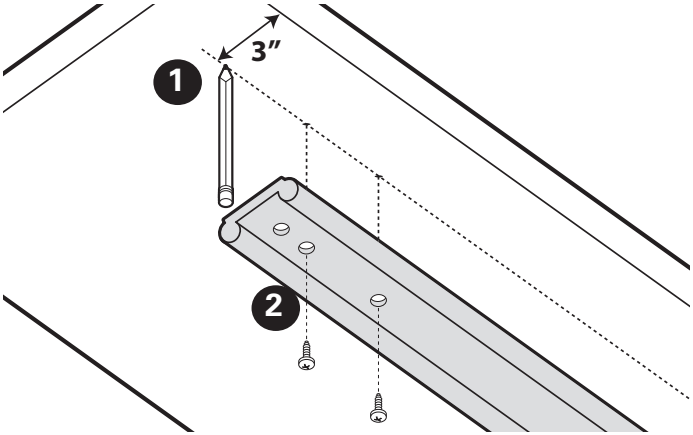

# BRIDGES II INSTALLATION GUIDE

## Round Table Supports

Round table structure consists of one main leg and two individual legs.

STEP 1: Put round top upside down on a clean flat surface.

STEP 2: Position each individual leg.

STEP 3: Secure the legs with supplied screws. Level the whole assembly.

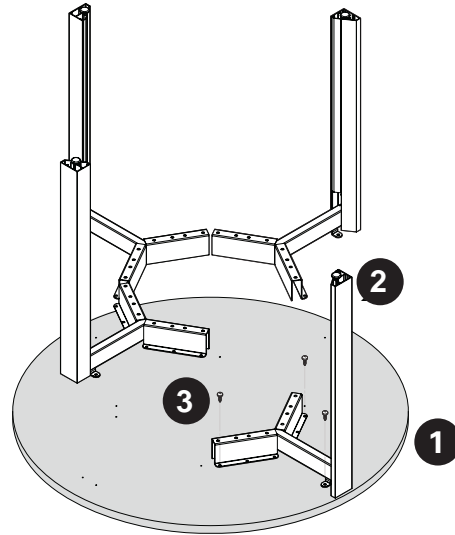

## Glide Tray Adapter Assembly

Both machine screws and wood screws are provided with each pair of brackets.

Assembly:

STEP 1: Position the brackets (as shown) on the flat side of the Glide Track to align the selected holes.

STEP 2: Attach the brackets to the Glide Track using the supplied machine screws. Push the screws through the holes in the Glide Track and thread them into the Nut Inserts.

STEP 3: Position the track and bracket assembly where desired on the underside of the worksurface and fix in place using the four supplied wood screws.

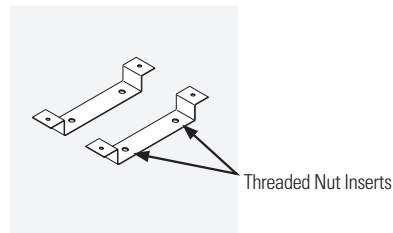

**Caution: The wood screws are designed to be used with 1" or thicker worksurfaces. Check to make sure the screws will not penetrate through the top of the surface.**

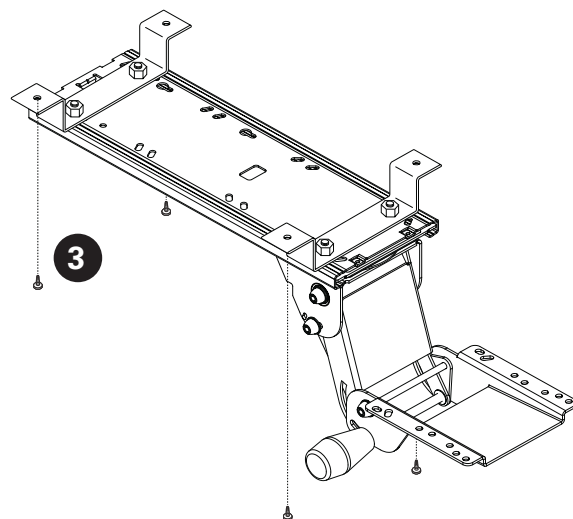
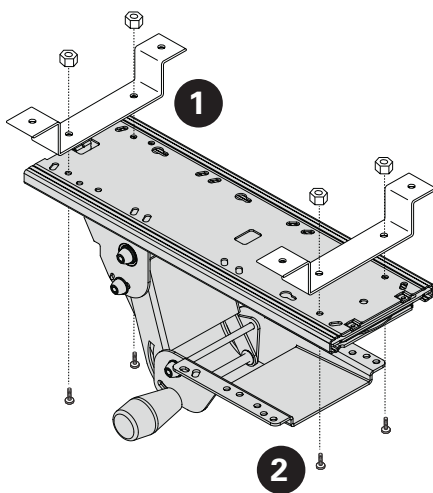

Power, Data and Cable Management

Overview

- Wire basket
- Above worksurface back-to-back power trough with base feed and ceiling feed
- Below worksurface back-to-back power trough with base feed
- Ceiling feed
- Below worksurface single-sided power trough with base feed
- Storage power box

Power Delivery / Cable Management

At the basic level, table and floor based office equipment is serviced by a wall or floor power supply. As the operation grows, there might be a need to organize excessive cable clutter.

**Wire basket (1)** connects to the underside of worksurfaces with sprig brackets and cables are simply dropped and coiled into them.

**Cable Snake(2)** installed in proximity of floor monument to manage vertical cable clutter.

Table clamped, single circuit **Desk Top Power Data Modules (3)** deliver services to desk height, while tapping into wall or floor power supply. Again, the excessive cables can be managed with Cable Trays.

**Ceiling pole BRTCPP (4)** manages power and data cables between ceiling and above or below worksurface power troughs.

**Above and Below Worksurface Power/Data Troughs (5)** can be installed between back-to-back tables for extended below and above desk height power / data distribution. - 8 wire, 4-circuit system.

**Single Sided Power/Data Troughs (6)** can be installed to the underside of a single table.

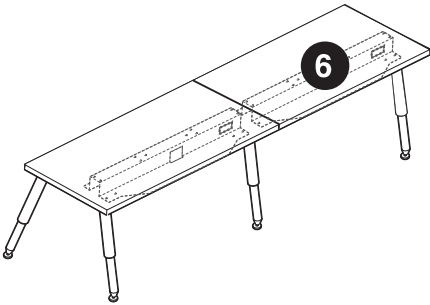
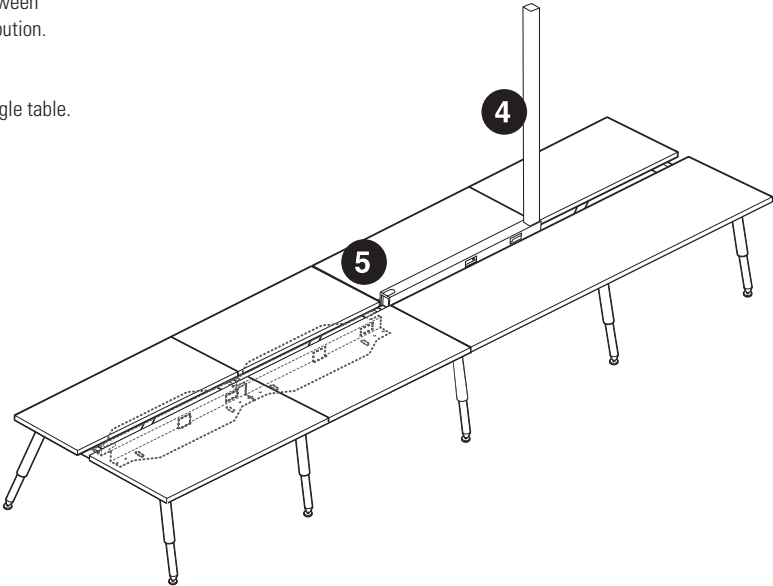
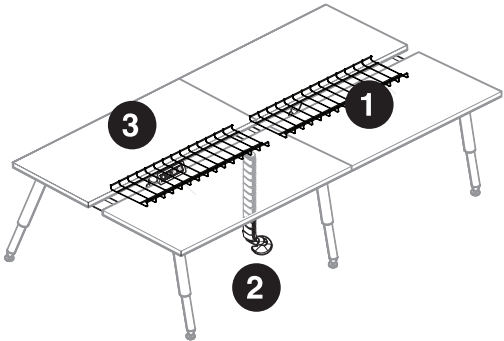

**Storage power/data box BRTVCM (7)** attaches to storage units and provides access to one duplex/data terminal on top storage surface. Integrated single circuit module can be plugged to floor monument under the storage or to a wall outlet.

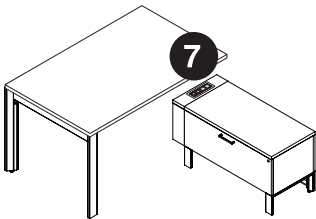

# BRIDGES II INSTALLATION GUIDE

## Wire Basket

### Wire Basket

8" wide basket manages cable excess under single and back-to-back worksurfaces, as well as under storage cabinets. It is suspended on four spring steel brackets so it can be easily unclipped to rearrange cable connections from below the worksurface or below storage units.

Wire baskets are available in incremental sizes, usually about 8" shorter than the intended worksurface / storage span.

STEP 1: Identify the correct basket length. Attach supplied spring brackets on the basket as illustrated so that the hooks point inward. Center the basket below worksurface.

STEP 2: Secure by driving supplied screws through the four brackets into the worksurface.

**Storage cabinet installation:** bottoms of storage cabinets are provided with pre-drilled holes. Attach supplied spring brackets on the basket so that the hooks point inward. Secure the baskets by driving supplied screws through the four brackets into the storage cabinet's bottom.

Long Wire Baskets can span under several storage cabinets. As a general rule, specify Cable Basket min. 8" shorter than the storage cabinet spine assembly.

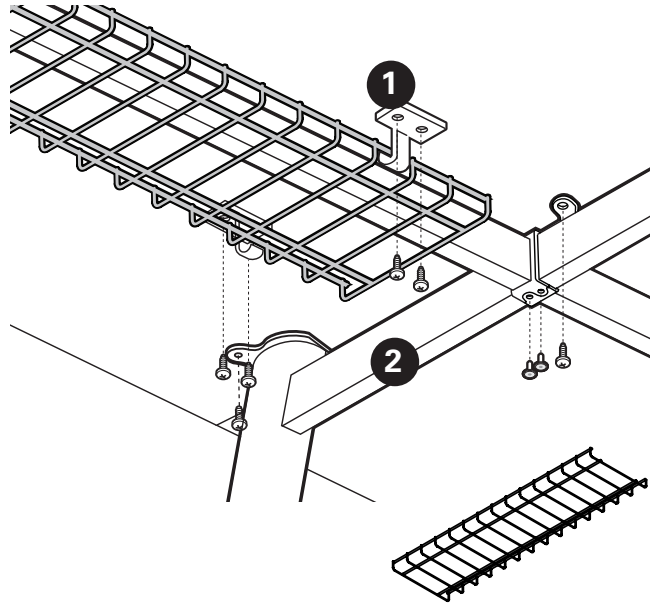

## Below Worksurface Power Trough

**NOTE:** Install dividers, storage and table top accessories prior to proceeding with the installation of below surface power trough.

### A) SUPPORTING STRUCTURE

Identify length and location of required Power Troughs and position them in accordance with lay-out plans. Install brackets on Power Troughs. Make sure that all Power Troughs are securely connected before proceeding with installation of electrical components.

### B) ELECTRIC COMPONENTS

Identify type and location of required electrical components and position them in accordance with lay-out plans. Secure Power Feed to the Power Trough brackets (ensure that the liquid tight whip is long enough to reach the power source / floor monument). Proceed with connecting Power Distribution Assemblies and Jumper Harnesses on the ground, just below their future location. Install Duplex Receptacles as specified. Secure interconnected electrical components to Power Trough.

### C) DATA/COMMUNICATION

Arrange cables below their future location into bundles under the tables. Install cable terminals and snap Terminal Plates into the openings in the middle of Power Trough. Proceed from one side of the table assembly, lift cable bundles and secure them to the Power Trough with extruded Data Cable Manager.

### D) CONNECT TO THE BUILDING POWER SUPPLY

It is recommended that the connection to the building power supply be made under the supervision of a licensed electrician and according to applicable codes and regulations. Connection to the building power supply must be done by a licensed electrician. Do not connect or disconnect components while the system is under load. Disconnect the main power before servicing or reconfiguration.

### E) WALK THROUGH / INSTALLATION INSPECTION

## Below Worksurface Power Trough Installation

STEP 1: Install four brackets (two pairs of left and right brackets are required). Below worksurface Power troughs are provided with 4 pairs of mounting holes to accommodate the brackets at various table leg positions.

Two back-to-back tables use narrower supporting beams and the legs on both sides are, therefore, inset below worksurfaces. To fit the Trough and brackets into this narrower space, use a pair of mounting holes "B - B" to secure below worksurface Power Trough to a single assembly of two back-to-back tables.

A back-to-back table assembly at the beginning of a multiple table run employs slightly longer supporting beams to accommodate the legs on the 'start-of-a-run' side to be inset below worksurfaces, and the shared leg to be right below the seam of two adjacent worksurfaces. Use a pair of mounting holes "B" to secure brackets to the Power Trough on the 'start-of-a-run' side, use the pair of mounting holes "A" to secure brackets to the Power Trough on the 'shared' leg side.

A back-to-back table assembly in the middle of a multiple table run employs the longest, interconnecting supporting beams - placing shared legs right under the seams of adjacent worksurfaces on both sides. Use mounting holes "A" on both sides to secure brackets to the Power Trough.

Position the Power Trough over the brackets so that threaded studs on the brackets protrude through the holes in the Power Trough. Secure brackets with supplied thumb nuts. NOTE: Ensure that trough ends are equidistant from worksurface ends.

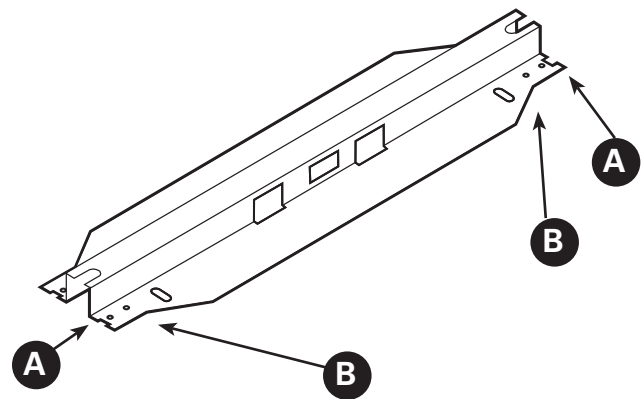

**Below Worksurface Power Trough Installation**

STEP 2: Engage Trough's brackets with the leg's horizontal beam. Ensure that tab "D" fits over the leg beam. Use tab "E" to locate the bracket against the leg worksurface bracket as illustrated.

STEP 3: Secure each bracket by driving supplied screws through tab "C" into the bottom of the worksurface.

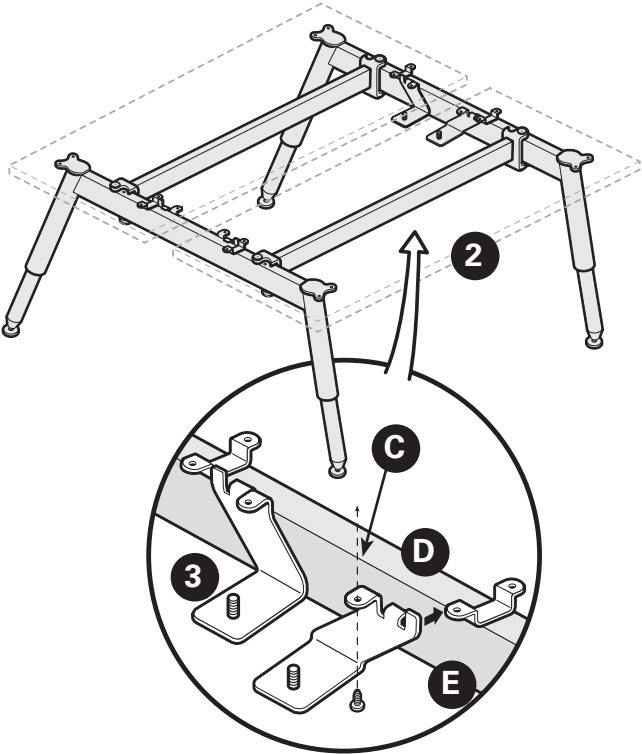

**Power Trough - 120° Installation**

Installation of 120° Power Troughs and Below worksurface Power Troughs on a worksurface supported by storage Towers.

120° Power Troughs and Power Troughs on a worksurface supported by storage Towers are secured to tables with two types of brackets: the standard trough-mounting brackets on one side (the same, above described rules apply: (A) position for shared application; (B) position for end of a run application) and narrow "Z" brackets securing the opposite side of the Power Troughs in the proximity of the 120° 'corner' leg or in the proximity of Storage Tower.

STEP 1: Install trough brackets

STEP 2: Preassemble "Z" brackets and power Troughs: Thread the threaded stud through the Power Trough as illustrated. (Notch in the front edge of the Power Trough prevents the "Z" bracket from rotating).

STEP 3: Engage Trough's brackets with the leg's horizontal beam. Ensure that tab "A" fits over the leg beam. Use tab "B" to locate the bracket against the leg worksurface bracket as illustrated.

STEP 4: Secure the Trough by driving supplied screws through tab "C" and through "Z" brackets into the bottom of worksurfaces.

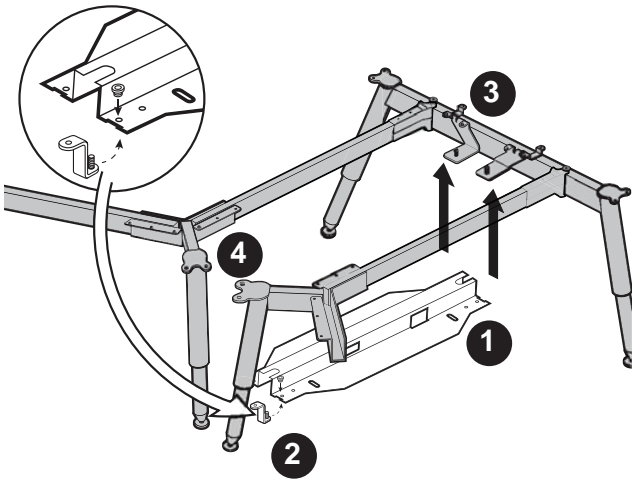

# BRIDGES II INSTALLATION GUIDE

## Power Trough Electric Components - Below Worksurface Trough Base Feed

Identify type and location of required electric components and position them in accordance with lay-out plans.

STEP 1: Secure Power Feed to the Power Trough brackets (ensure that the liquid tight whip is long enough to reach the power source / floor monument).

STEP 2: Lift the Power Trough on one side and rest the Power Feed mounting bracket on top of the Power Trough brackets.

STEP 3: Lower the Power Trough so that the Power Feed bracket is sandwiched between the Power Trough and Power Trough supporting brackets; ensure that threaded studs protrude through the holes in the Power Trough.

STEP 4: Secure all Power Troughs with supplied knurled thumb nuts.

STEP 5: Connect Power Distribution Housings and Jumper Harnesses on the ground, just below their future location.

NOTE: There is an arrow and a letter "N" on each Power Distribution Housing and on every Jumper Harness referring to the correct position in relation to each other.

STEP 6: Install Duplex Receptacles as illustrated, with circuit numbers in accordance with the electrical plans.

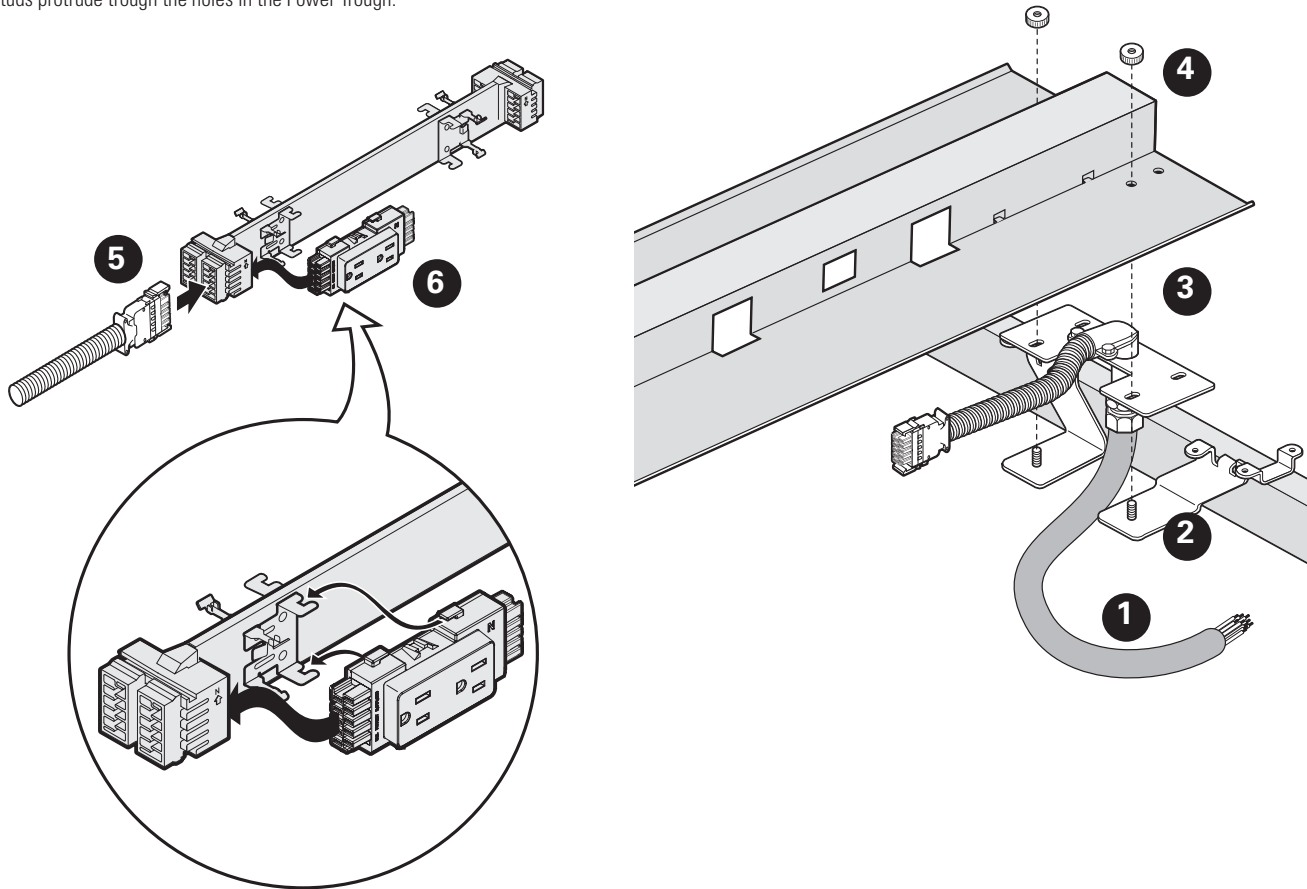

**Power Trough Electric Components : Continued**

STEP 7: Secure interconnected Electrical Components to Power Troughs: Proceed from the Power Feed by connecting its harness to the Power Distribution Housing.  
NOTE: There is an arrow and a letter "N" on each Power Distribution Housing and every Power Feed referring to the correct position in relation to each other.

STEP 8: Insert assembled Electrical Components into the Power Trough from the bottom. Ensure that all four Duplex Receptacles are located in their designated openings.

STEP 9: Insert Power Distribution Housing Lock into the gap between Power Trough and the bottom of the Duplex Receptacle.

STEP 10: Slide back to engage the opposite end as illustrated.

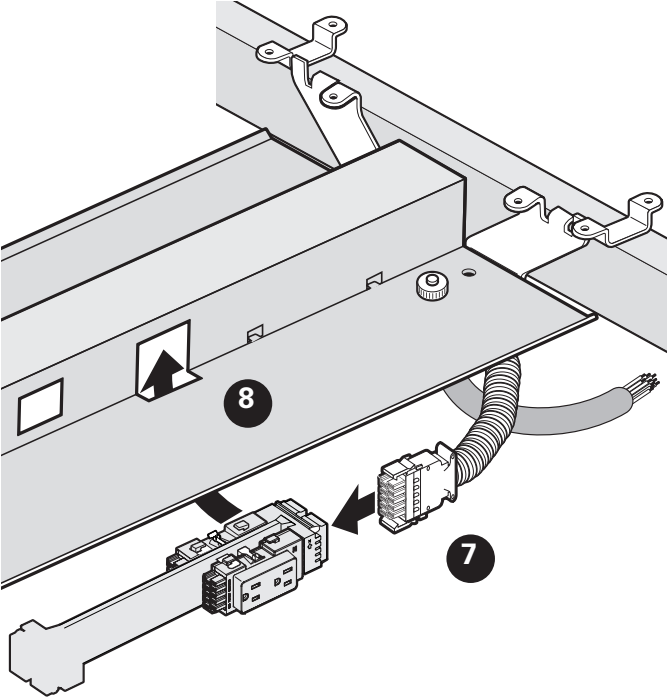

Organize data/communication cables on the ground, just below their future location.

STEP 12: Thread cable through data/communication opening (located in the middle of each Power Trough). Connect terminals and snap terminal plate into data/communication opening.

STEP 13: Capture cable bundles in the extruded Data Cable Manager trough

STEP 14: Snap Data Cable Manager Trough into the bottom of Power Trough. Ensure that data/communication troughs are securely engaged with all tabs at the bottom of Power Troughs. (Refer to actual part).

STEP 11: Repeat steps 9 and 10 under the opposite Duplex Receptacle. Proceed to the opposite end of Power Distribution Housing.  
Ensure that all electrical components are interconnected and secured to Power Troughs.  
Connect Power Feed to the building power supply.

**NOTE: There must be only one power feed entry into each cluster of harnesses. WARNING! It is recommended that installation of the wiring system be made under the supervision of a licensed electrician in accordance with applicable codes and regulations. Connection to the building power supply must be done by a licensed electrician. Do not connect or disconnect components while the system is under load. Disconnect the main power before servicing or reconfiguration.**

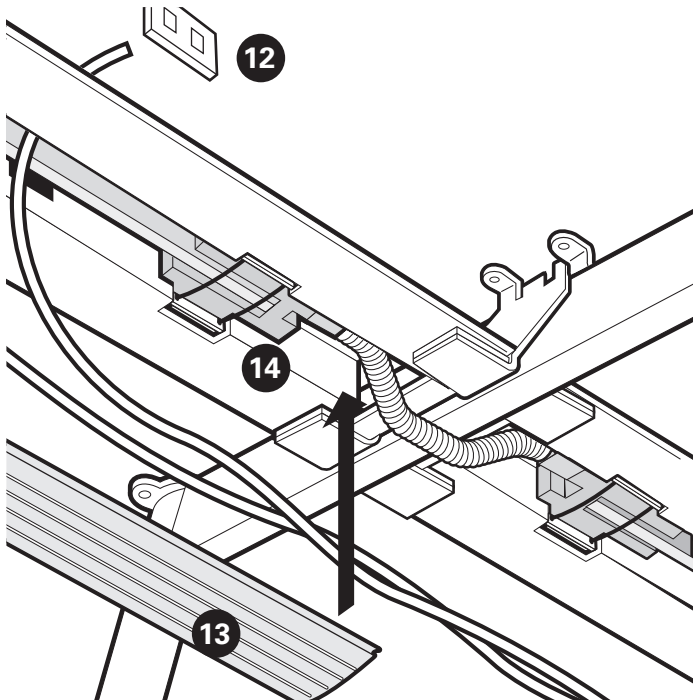
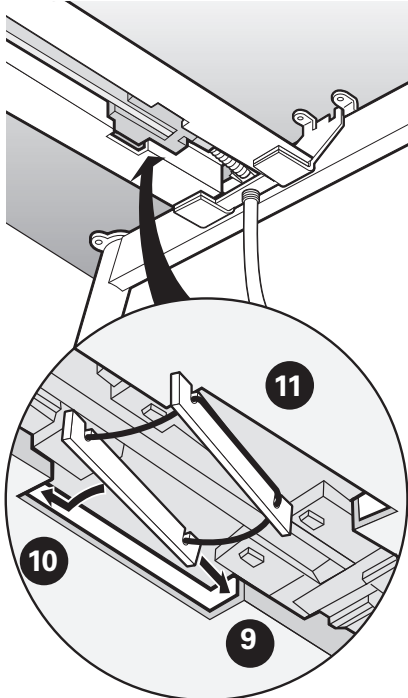



## Single Sided Power Trough

STEP 1: Identify correct length of Single- sided Power Trough and position it up against the bottom of worksurface so that its shorter lip rests against the table supporting beam.  
Center it sideways so that its center becomes aligned with the center of the worksurface.

STEP 2: Secure it to the worksurface with supplied screws.

Identify type and location of required electric components and position them on the floor in accordance with lay-out plans.

STEP 3: Install Duplex Receptacles, with circuit numbers in accordance with the electrical plans. NOTE : There is an arrow and a letter "N" on each Power Distribution Housing, Duplex receptacle and on every Jumper Harness referring to the correct position in relation to each other.

STEP 4: Connect Power Distribution Housings, Jumper Harnesses and Base feed.

STEP 5: Slide Power Distribution Housing with Duplexes, Jumpers and Base feed into the Trough. Ensure that all Duplexes are properly seated in the openings.

STEP 6: Secure with supplied 1/4-20 screw and special die-cast washer. See detail illustration. The screws lead through the gap between Power Distribution Module terminals and into two weld-nuts inside the Trough.

STEP 7: Align Base feed plate with 4 threaded inserts on the Trough and secure with four supplied #10-24 screws.

STEP 8: Thread data/communication cables through Trough terminal opening and make jack/terminal plate connections.

STEP 9: Scoop up data/communication cables into the cable manager and snap the manager into the Trough while making sure that the groove in the extruded manager is engaged with all inwardly pointing Trough tabs.

Ensure that all electrical components are interconnected and secured to Power Troughs. Connect Power Feed to the building power supply.

**NOTE: There must be only one power feed entry into each cluster of harnesses.**  
**WARNING! It is recommended that installation of the wiring system be made under the supervision of a licensed electrician in accordance with applicable codes and regulations. Connection to the building power supply must be done by a licensed electrician. Do not connect or disconnect components while the system is under load. Disconnect the main power before servicing or reconfiguration.**

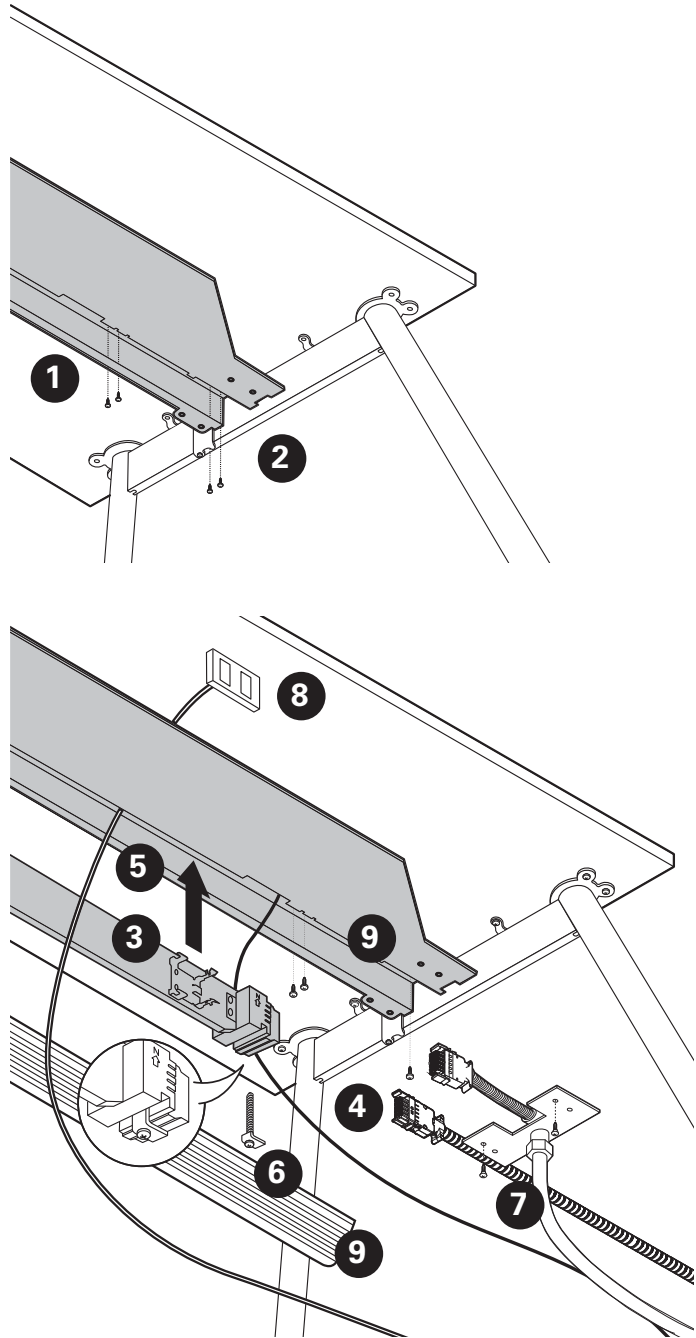

**Above Worksurface Power Trough**

Identify correct length of Above Worksurface Power Troughs and place them on worksurface in their respective locations.

Identify type and location of required electric components and position them in accordance with lay-out plans.

STEP 1: Install Duplex Receptacles, with circuit numbers in accordance with the electrical plans. NOTE : There is an arrow and a letter "N" on each Power Distribution Housing, Duplex receptacle and on every Jumper Harness referring to the correct position in relation to each other.

STEP 2: Connect Power Distribution Housings and Jumper Harnesses.

STEP 3: Thread Base feed's metal conduit with connector between worksurfaces, Connect Power Feed to the Power Distribution Module (ensure that the liquid tight whip is long enough to reach the power source / floor monument). If the plans call for Ceiling feed then connect it with Power Distribution Housing and let the rest of the metal conduit rest on the worksurface for now.

STEP 4: Slide Power Distribution Housing with Duplexes, Jumpers and Power feed into the Above Worksurface Power Trough. Ensure that all Duplexes are properly seated in the openings. and secure with supplied 1/4-20 screw and special die-cast washer. See detail illustration. The screws lead through the gap between Power Distribution Module terminals and into two weld-nuts inside the Trough.

STEP 5: Slide four Duplex retainers into the Power trough openings. Lower tabs of the retainer are provided with semi - spherical protrusions which snap into holes in the Power Trough - thus keeping the Duplexes in place.

STEP 6: Slide Ceiling feed opening cover in place if you are using Base feed; leave it off if you are using Ceiling feed.

STEP 7: Install Above Worksurface Power Trough End covers at the end of a trough run. No covers are installed between two adjacent Above Worksurface Power Troughs. Secure the End covers with two supplied screws. Ensure that the covers are aligned with sheet metal case of the Trough.

STEP 8: Lower the assembly into the gap between back-to-back worksurfaces

STEP 9: Insert bracket's tab in vertical position into elongated slots in Above Worksurface Power Trough.

STEP 10: Rotate the bracket upward

STEP 11: Secure brackets with supplied screws

STEP 12: Align Power Feed's mounting plate with Above Worksurface Power Trough and secure it to worksurface with four supplied screws.

STEP 13: Thread data/communication cable past the Power Distribution Module and out through data/com opening. Make cable / terminal jacks / terminal plate connections and snap terminal plate into the Above Worksurface Power Trough.

STEP 14: Scoop up data/communication cables into the cable manager and snap the manager into the Above Worksurface Power Trough while making sure that the groove in the extruded manager is engaged with all inwardly pointing Above Worksurface Power Trough tabs.

Ensure that all electrical components are interconnected and secured to Power Troughs. Connect Power Feed to the building power supply.

**NOTE: There must be only one power feed entry into each cluster of harnesses.**  
**WARNING! It is recommended that installation of the wiring system be made under the supervision of a licensed electrician in accordance with applicable codes and regulations. Connection to the building power supply must be done by a licensed electrician. Do not connect or disconnect components while the system is under load. Disconnect the main power before servicing or reconfiguration.**

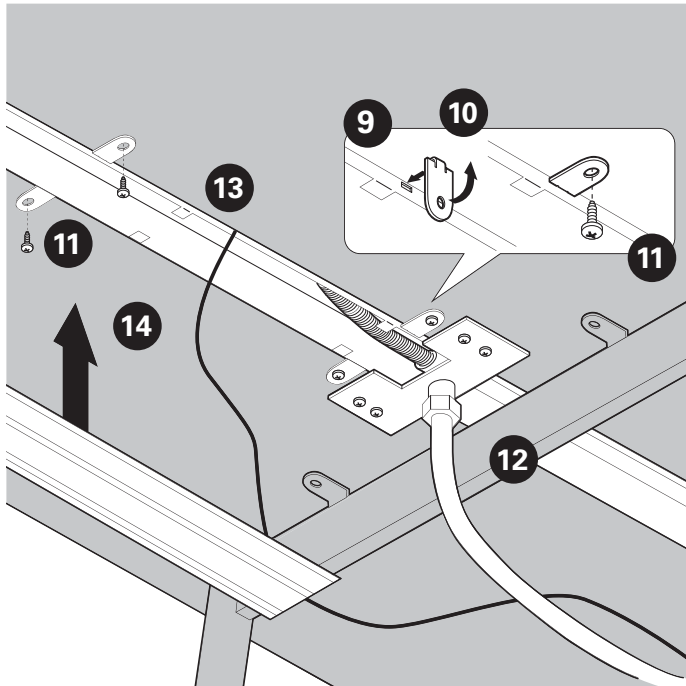
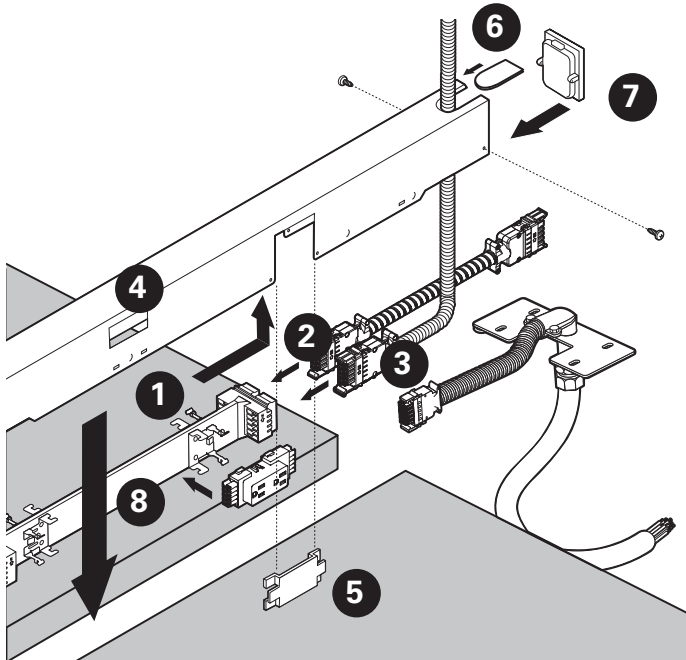

# BRIDGES II INSTALLATION GUIDE

## Back-to-Back Storage Tower Gap Filler Kit

Cover Trough's installation consists of securing four brackets to worksurfaces immediately adjacent to storage towers. Brackets can be installed in two positions, which determine whether the trough cover is going to function as an Above or Below worksurface trough cover.

### Above worksurface application.

- STEP 1: Hold bracket against storage tower corner (panels A and B).
- STEP 2: Secure four brackets by driving supplied screws into the worksurfaces, through two adjacent holes on the opposite end of the bracket as illustrated.
- STEP 3: Lower the trough cover between the storage tower. The bottom of the trough will rest on top of the bracket.

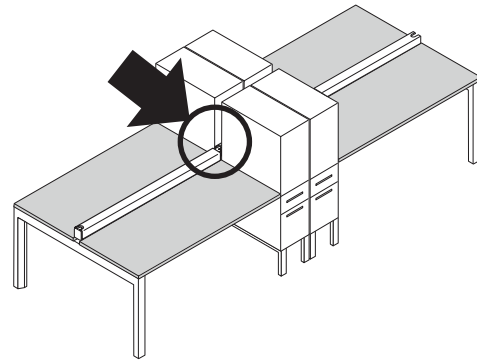

### Below worksurface application.

- STEP 4: Begin as above, by holding the bracket against the storage tower corner (panels A and B)
- STEP 5: Slide the bracket away from the tower until tip of bracket C lines up with the end of the worksurface (or storage panel B)
- STEP 6: Secure four brackets by driving supplied screws into the worksurfaces through two holes as illustrated.
- STEP 7: Lower the trough cover between the storage tower. The top of the trough will rest on the front tip of the bracket.
- STEP 8: Scoop up power and data cables and secure them to the trough with supplied rubber O ring.

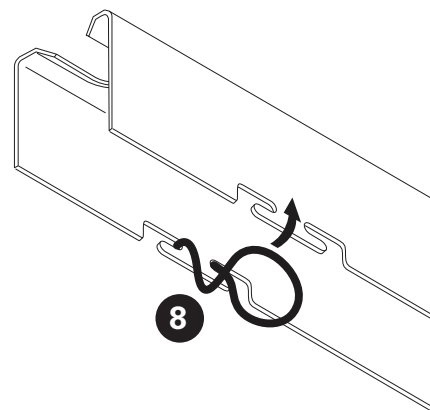
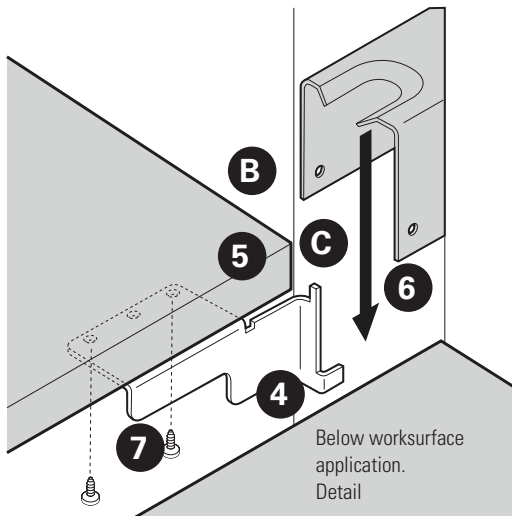
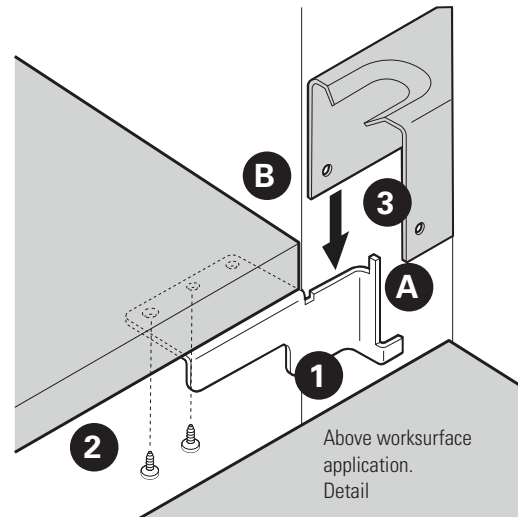

**BRTDLSHS34 Shroud**

STEP 1: Complete installation of tables, worksurfaces, power troughs, power outlets and data/communication cables.

STEP 2: Remove vertical cable manager from both legs. Engage tabs at either bottom end of the shroud with the groove in the legs (the same groove Vertical Cable Managers snap into).

STEP 3: Rotate the shroud up, into vertical position while making sure that the bottom tabs remain engaged in the leg groove.

STEP 4: Secure the shroud to worksurfaces with supplied screws (6 screws per shroud).

STEP 5: Follow the same procedure to install the second shroud on the opposite side of the leg.

STEP 6: Scoop up the data/communication cables into the cable manager and snap the manager into the power trough while making sure that the groove in the extruded manager is engaged with all inwardly pointing trough tabs.

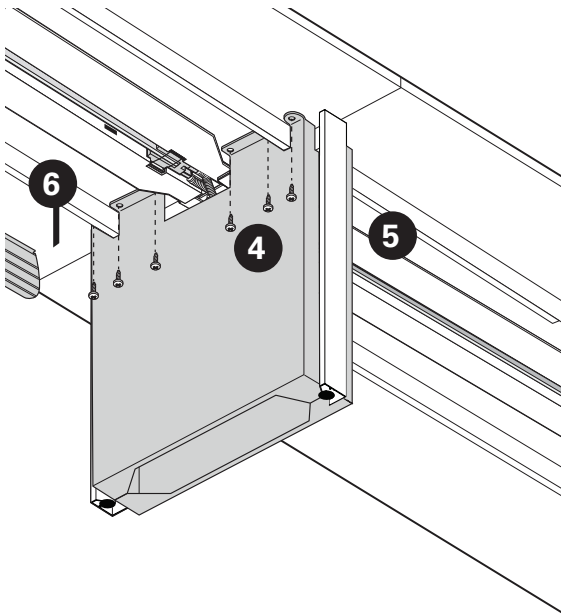
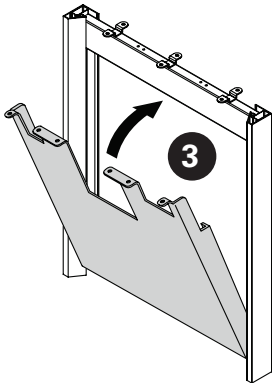
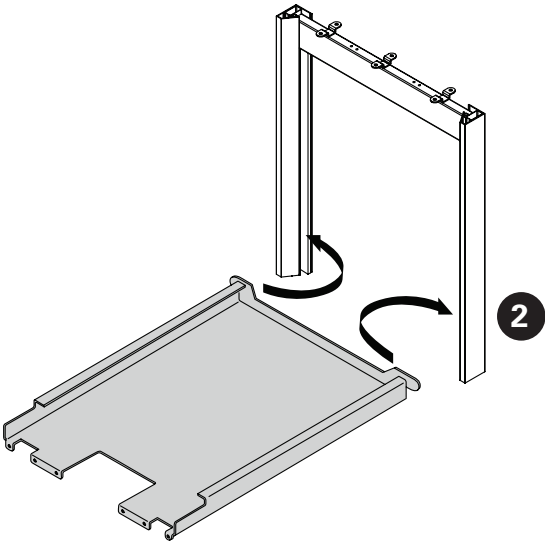
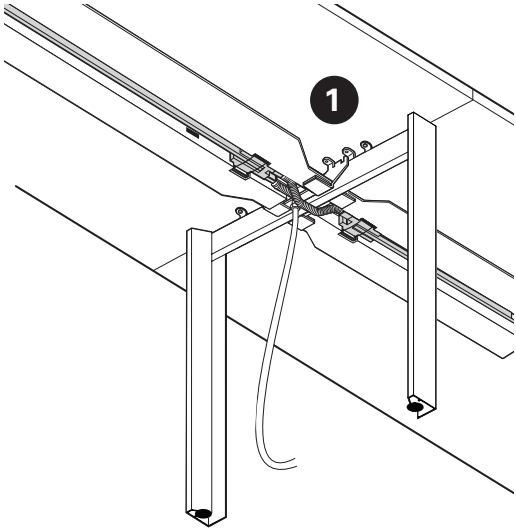

# BRIDGES II INSTALLATION GUIDE

## Ceiling Feed

Ceiling feed pole kit consists of a two-part vertical channel and two handed bottom brackets.

Ceiling feed pole installation on Above and Below Power troughs is identical. Above trough is illustrated. Ceiling feed harness has already been connected to the Power Distribution Module and data / communication cables, hanging from the ceiling, enter designated Power trough through its grommet.

STEP 1: Secure bottom brackets to the bottom of the extruded pole with four supplied screws as illustrated.

STEP 2: Organize data / communication cables and the ceiling feed metal conduit within the pole and snap the pole cover closed.

STEP 3: Insert Ceiling feed junction box bracket into the top of the channel.

STEP 4: Position the assembled pole over the Power trough.

STEP 5: Mark and cut hole in the ceiling tile. Reinstall the ceiling tile and secure top of the Ceiling feed pole to the ceiling tile grid.

STEP 6: Connect the Ceiling feed harness to the building power supply.

**NOTE: There must be only one power feed entry into each cluster of harnesses. WARNING! It is recommended that installation of the wiring system be made under the supervision of a licensed electrician in accordance with applicable codes and regulations. Connection to the building power supply must be done by a licensed electrician. Do not connect or disconnect components while the system is under load. Disconnect the main power before servicing or reconfiguration.**

STEP 7: Slide a two-part Ceiling feed bezel over the pole and secure it to the ceiling tile with supplied screws.

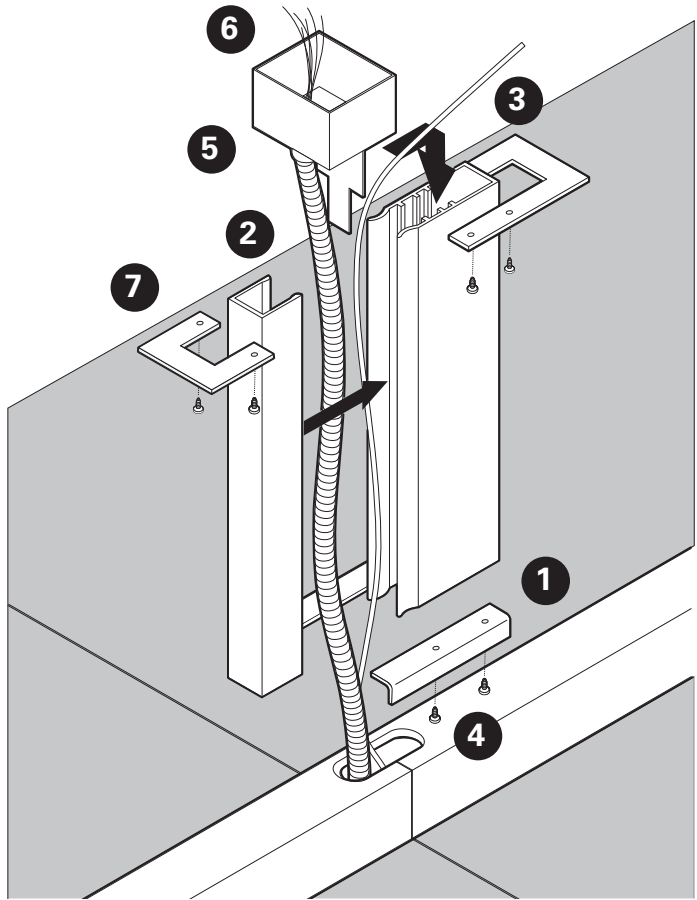

### Ceiling feed and divider application on below worksurface power trough

Specify and install divider nominally 6" shorter than the worksurface. Divider brackets remain in the same position.

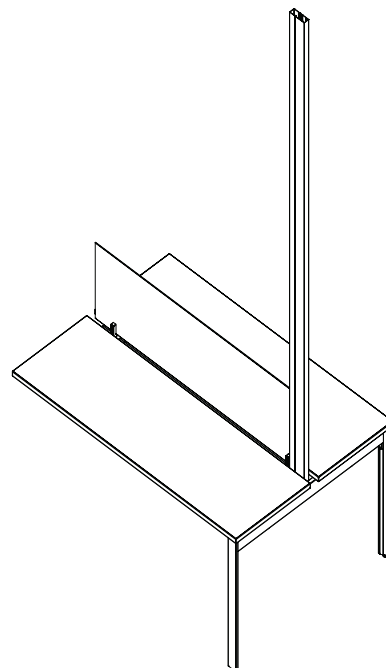

**Power Distribution Storage Power Box**

In order to secure Storage power box to Storage cabinets it is necessary to reposition one of the storage supporting legs so that it will support the Storage power box as well.

Every storage leg is provided with two hole patterns: 3+3 holes positioned closer to the edges of the leg extrusion and 2+2 hole pattern closer to the center of the extrusion.

**STEP 1:** Remove six screws securing the leg to the bottom of the storage unit. (3+3 hole pattern). Three of the six screws are machine thread screws. Store them in a safe place in case you will need to relocate the storage leg again in future. The remaining three long screws will be used.

**STEP 2:** Move the leg so that one half is located under the storage bottom, while the other half remains exposed. Align two of the 2+2 pattern holes with pre-drilled holes in the storage unit gable. Use an Allen key to secure the leg with two screws.

**STEP 3:** Rest the Storage power box on the leg, press it against the storage cabinet side gable. Use Allen key to secure the bottom of the Storage power box with two screws.

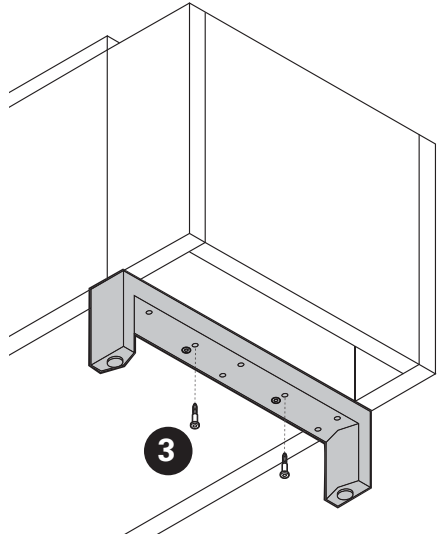
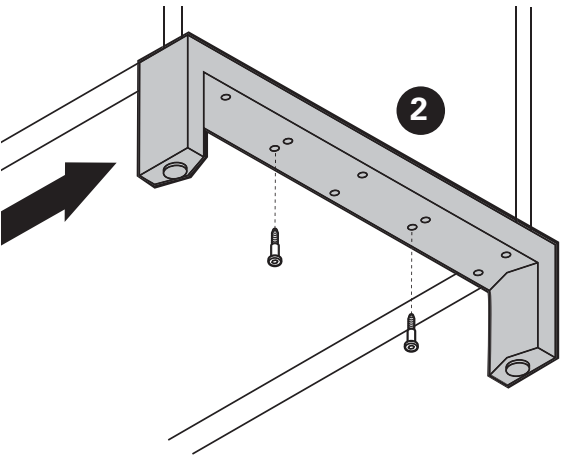
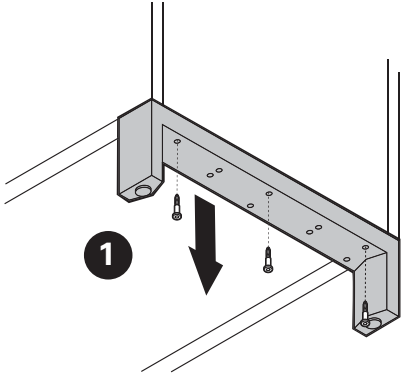

**STEP 4:** Lower top bracket (Left and Right brackets required) into the corner adjacent to the storage unit and rotate it so that the single-hole end of the bracket slides under storage unit top as illustrated.

**STEP 5:** Align the bracket with two pre-drilled holes and secure with supplied screws. Install the second bracket on the opposite side.

**STEP 6:** Open cabinet's door, drawer (removal of the drawer might be necessary) and secure both brackets to the storage unit's top with supplied wood screws.

**STEP 7:** Follow installation instructions included with the outlet/data module to secure it to the Storage Power Box top. Connect power / data cables and push the top over the box until the four connector pins snap in place.

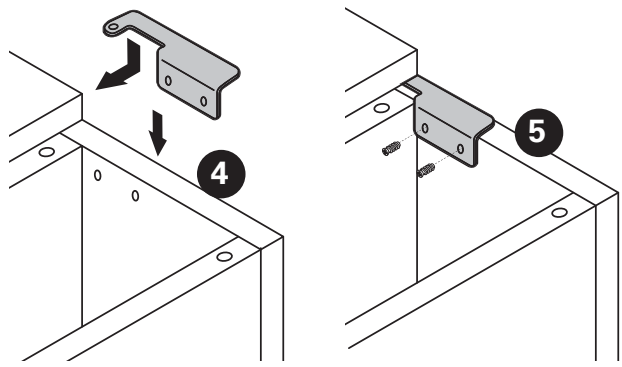

Organize cables under storage cabinets by installing Cable basket.

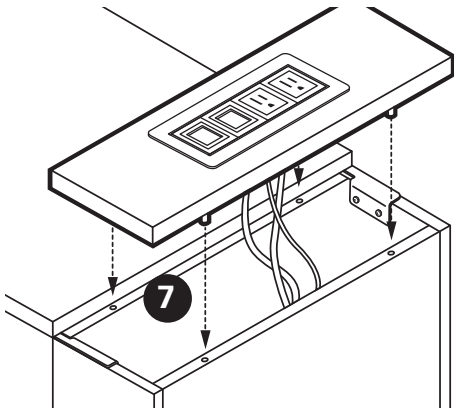
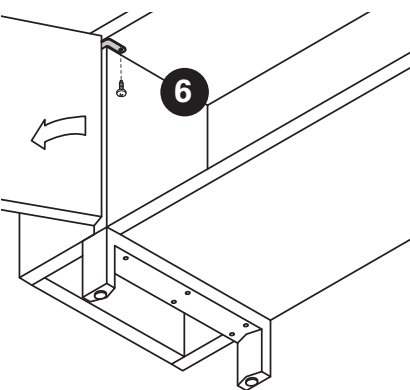

# BRIDGES II INSTALLATION GUIDE

## Parallel Dividers, Back-to-Back Tables, Glass And Laminate

36", 42", 48", 54", 60" and 72" wide dividers have two back-to-back divider brackets.  
78" and 84" dividers have three.

STEP 1: Back-to-back divider brackets can be set up to support glass dividers and laminate dividers as well.

To install **laminated** dividers insert the vertical brackets in the farthest positions A and secure them with screws C. Ensure that the screws are very tight.

To install **glass** dividers bring the vertical brackets snugly together B and secure them with screws C. Ensure that the screws are very tight.

STEP 2: Back-to-back worksurfaces are provided with pilot holes for accurate location of Back-to-back divider brackets. Align the brackets with pilot holes and secure with supplied screws.

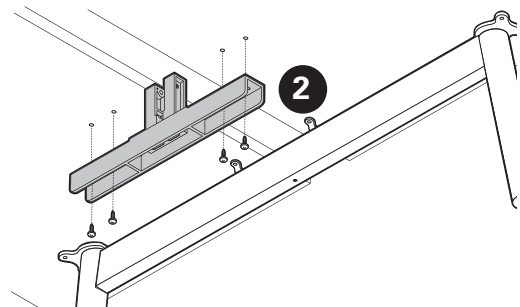
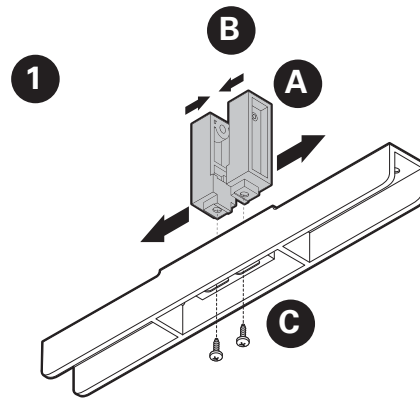

STEP 3: Insert the glass or laminate divider into the bracket while making sure that it is seated all the way at the bottom, resting on shock-absorbent pads.

STEP 4: Use Allen key to gently adjust plastic set screws while keeping the divider in vertical position. Do not over tighten!

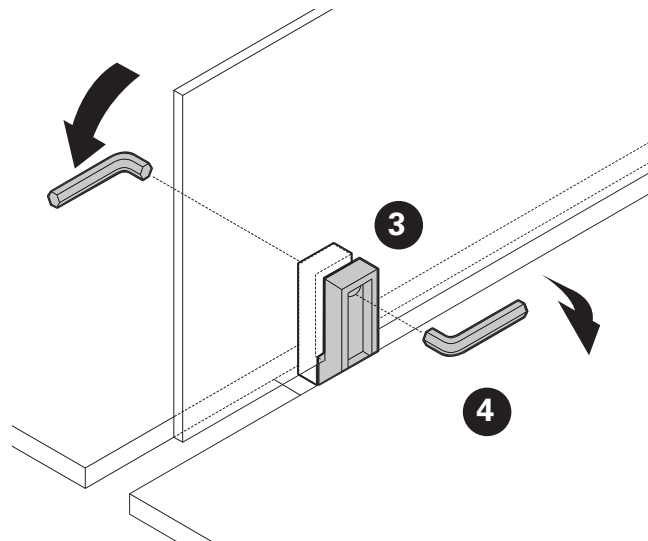

**Side-to-Side Laminate Divider**

Note: Side-2-side laminate divider can be installed in the middle of a worksurface and over two adjacent worksurfaces supported by round legs. Because rectangular legs occupy bottom corners of worksurfaces it cannot be installed over two adjacent worksurfaces unless they are supported by 34" deep Back-to-back leg.

STEP 1: Align the front bracket with pilot holes at the bottom of Side-to-side laminate divider and secure with supplied screws.

STEP 2: Slide the divider over the front edge of a worksurface at the desired location.

STEP 3: Align the rear bracket with pilot holes at the rear edge of Side-to-side laminate divider and secure with supplied screws.

STEP 4: Adjust divider's position and secure it to worksurface with supplied screws as illustrated.

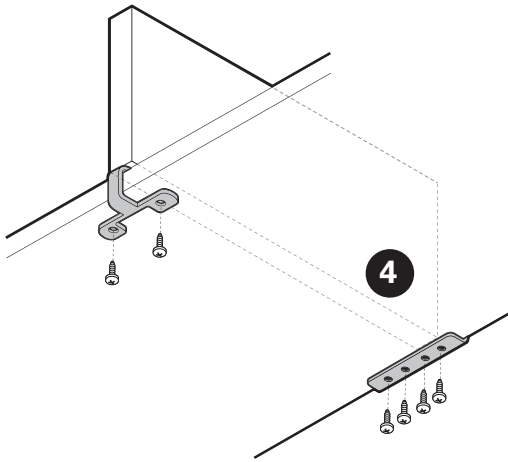
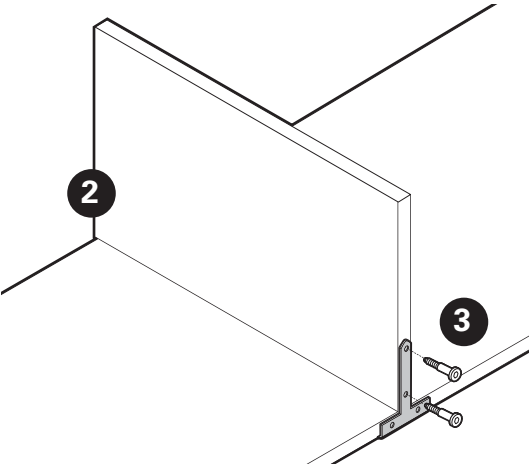
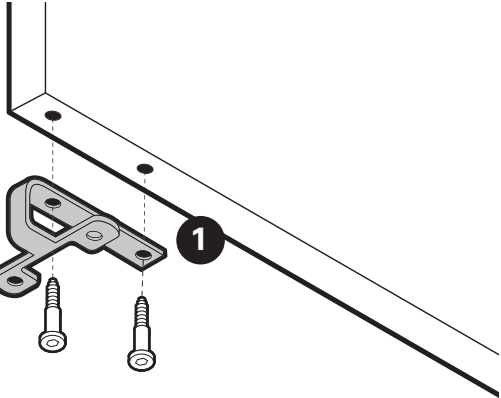
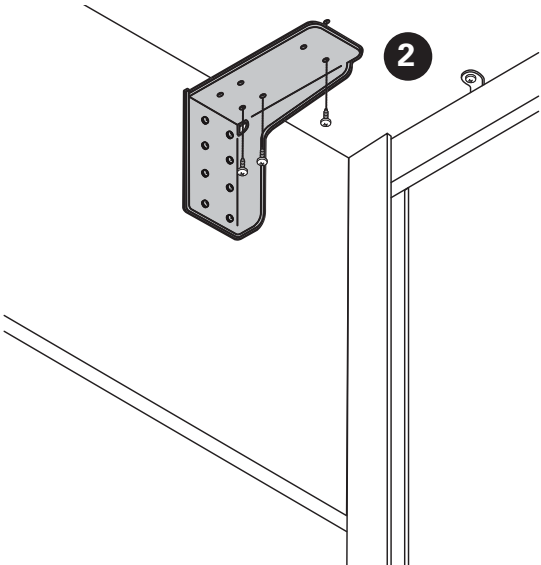
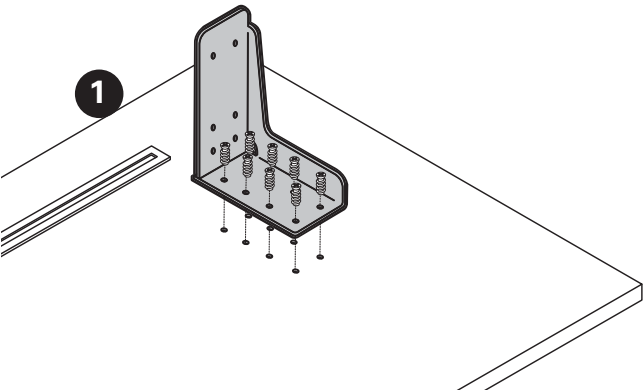
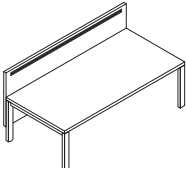

**Table Mounted Divider With Integrated Modesty Panel, Laminate**

Laminate parallel dividers are provided with 8 pilot holes.

STEP 1: Align the brackets with pilot holes and secure with supplied screws.

STEP 2: Have two people hold the divider with pre-installed brackets against the bottom of the table worksurface. Align the brackets with pilot holes in the worksurface as illustrated and secure with supplied screws. Drive in remaining screws.





# BRIDGES II INSTALLATION GUIDE

## Perpendicular, End of Run

Note: the Perpendicular end-of-a-run divider can only be installed on rectangular legs. Remove vertical cable manager cover from both legs.

STEP 1: Align top brackets with pilot holes and secure with supplied screws.!

STEP 2: Slide the end-of-a-run divider top brackets between top of leg's horizontal beam and the bottom of the worksurface and secure with supplied screws. Note: two screws per each bracket.

STEP 3: Insert and rotate the end-of-a-run divider bottom bracket into the leg, slide it up against the bottom end-of-a-run divider edge.

STEP 4: Align the brackets with pilot holes in as illustrated and secure with supplied screws.

Trim the vertical cable manager cover and snap it back in place.

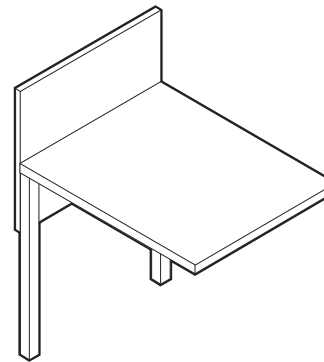
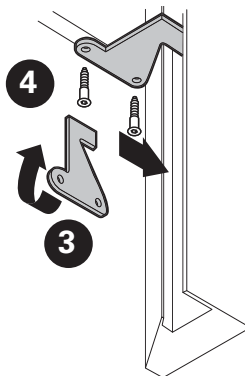
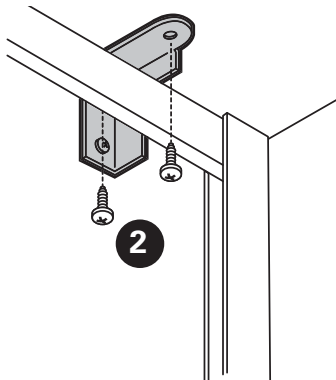
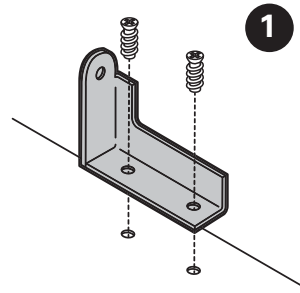

## Modesty Panel

Recessed modesty panel flip down bracket kit consists of two pairs of brackets.

**STEP 1:** Position the small brackets on the modesty panel so that the bracket's wall with single hole **A** faces outer edge of the modesty.  
Align brackets with pilot holes and secure with supplied screws. Ensure that the two supplied shoulder screws **B** are installed in the top, smaller holes (one per each bracket).

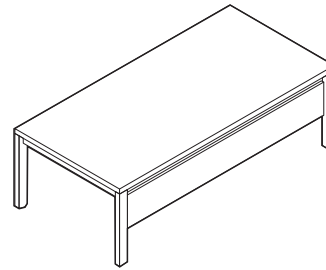

**STEP 2:** Position the large brackets against the bottom of the worksurface panel so that the bracket's wall with the oblong hole **C** faces table legs.  
Align the second hole **D** (close to the bracket's bend) with the third pilot hole **E** and secure with supplied screws. Ensure that the brackets are perpendicular to the worksurface's edge and secure the remaining screws.

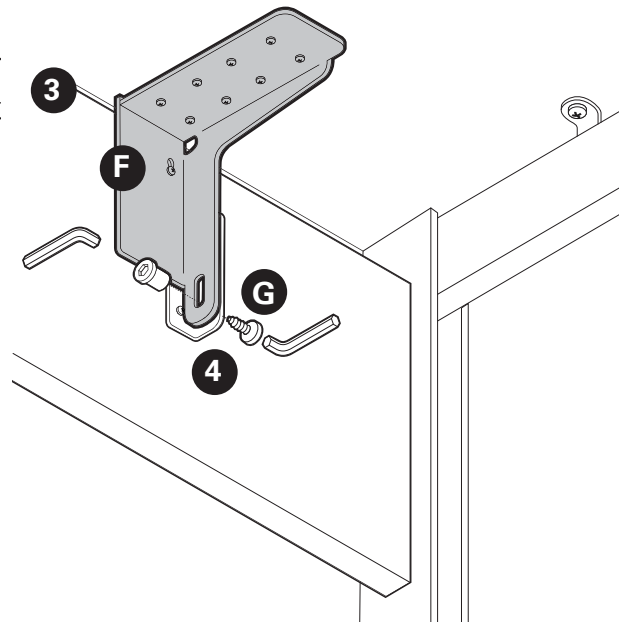
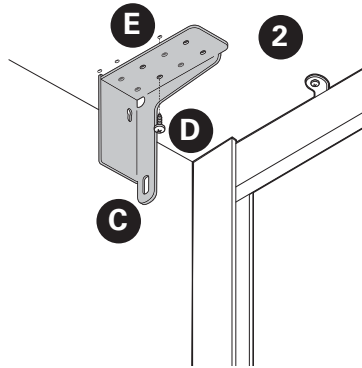
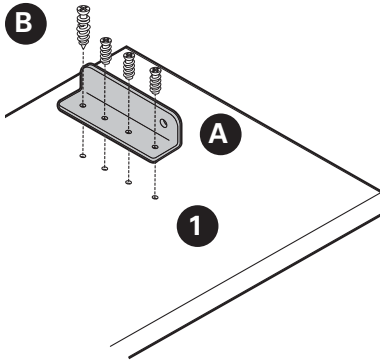

**STEP 3:** Suspend the modesty panel off the brackets by inserting both shoulder screws through the bracket's keyholes **F**.

**STEP 4:** Install joint connector screw as illustrated - the threaded stem screw **G** coming in from the leg side. Tighten with Allen keys.

**STEP 5:** Hold the center top edge of the modesty panel with one hand and the center bottom edge of the modesty panel with the other hand.  
Lift the modesty panel gently upward, making sure that both sides move up evenly. Pull the top edge gently out to disengage both shoulder screws and rotate downward.

Ensure that opening and closing action is smooth and both shoulder screws engage the keyholes easily.

# BRIDGES II INSTALLATION GUIDE

## Half Height Rectangular Leg Gable

Note: Rectangular leg gables can only be installed on rectangular legs. Proceed by removing vertical cable manager cover from both legs first.

STEP 1: Align top brackets with pilot holes and secure with supplied screws.

STEP 2: Align bottom brackets with pilot holes as illustrated and secure with supplied screws.

STEP 3: Slide the bottom brackets under the bottom of the leg extrusion.

STEP 4: Wiggle the gable slightly up while making sure that both bottom brackets are engaged with the leg extrusion.

STEP 5: Rotate into vertical position until both top brackets come between the bottom of the worksurface and the horizontal leg beam.

STEP 6: Secure the top brackets with two supplied screws while making sure that the bottom tabs remain engaged in the leg groove.

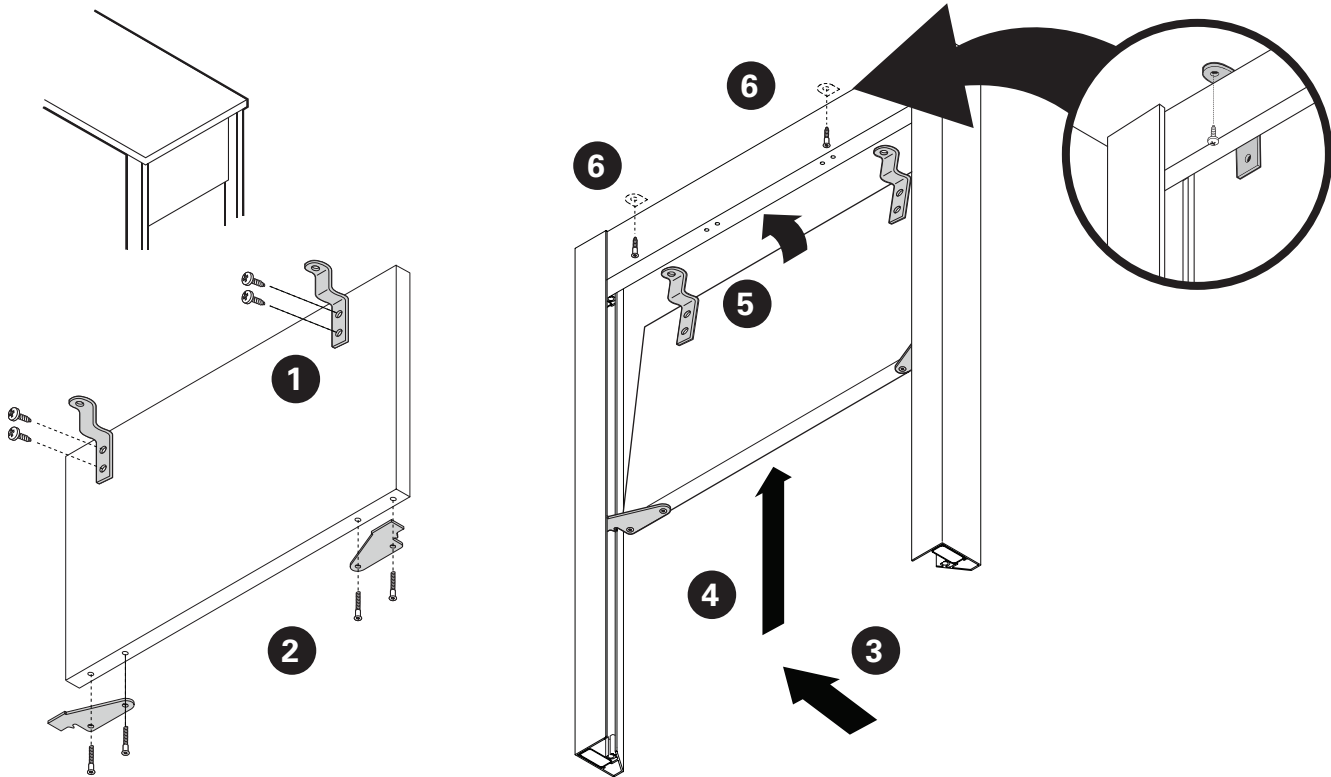

**Full Height Rectangular Leg Gable**

Note: Rectangular leg gables can only be installed on rectangular legs. Proceed by removing vertical cable manager cover from both legs first.

STEP 1: Align top brackets with pilot holes and secure with supplied screws.

STEP 2: Align bottom brackets with pilot holes as illustrated and secure with supplied screws.

STEP 3: Slide the bottom brackets under the bottom of the leg extrusion.

STEP 4: Wiggle the gable slightly up while making sure that both bottom brackets are engaged with the leg extrusion.

STEP 5: Rotate into vertical position until both top brackets come between the bottom of the worksurface and the horizontal leg beam.

STEP 6: Secure the top brackets with two supplied screws while making sure that the bottom tabs remain engaged in the leg groove.

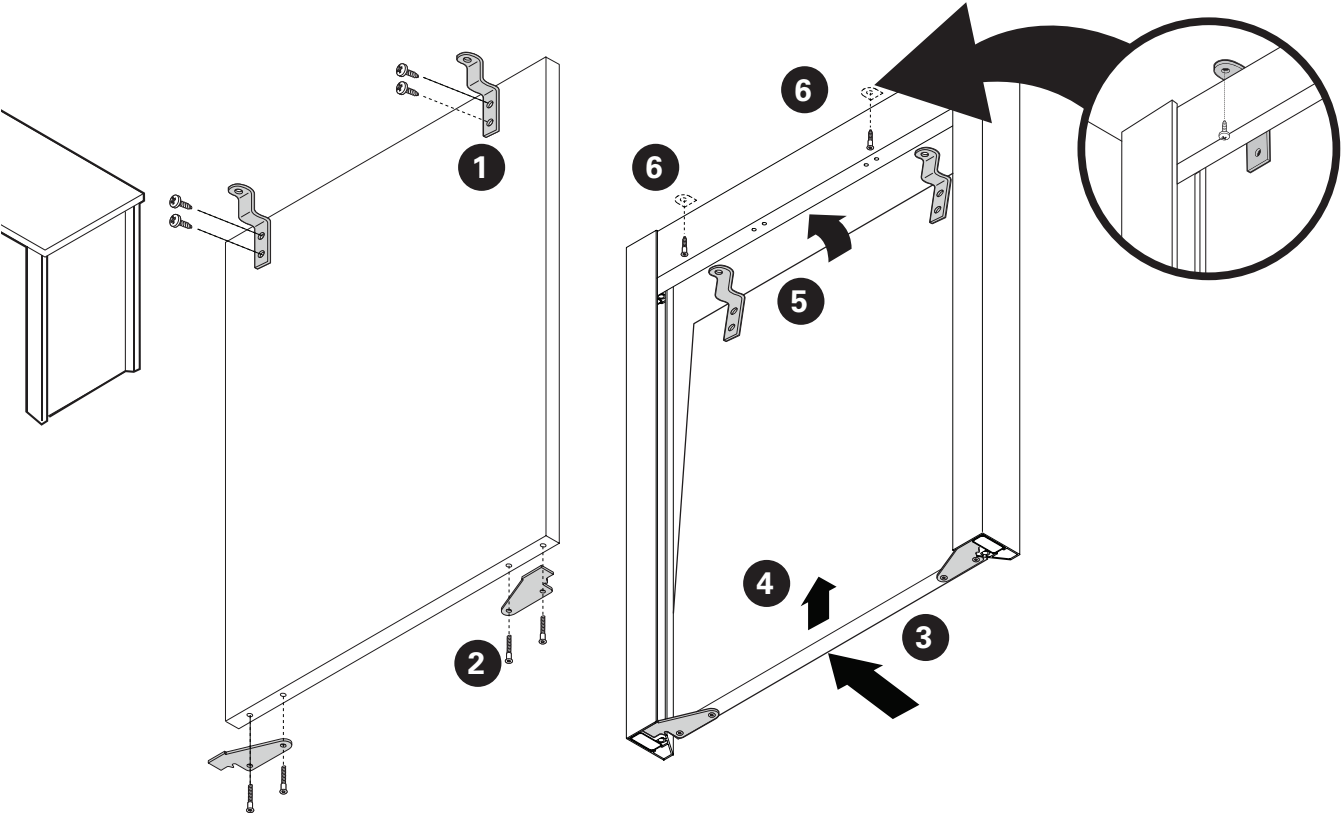

# BRIDGES II INSTALLATION GUIDE

## Table Mounted Divider with Integrated Modesty Panel, Glass

Secure Bracket to the glass.

STEP 1: Slide Rubber washer onto threaded studs.

STEP 2: Slide Spacers on the threaded studs with flange first.

STEP 3: Position bracket onto the glass and secure with two anodized caps.

STEP 4: Insert a pin into the hole in the cap and tighten.

STEP 5a: Have two installers hold the divider. Align the edges of both brackets with the back edge of the worksurface and center the brackets equidistantly between the table legs.

STEP 5b: Have two installers hold the glass modesty panel. Align the edge of the modesty panel with the inner edge of the leg. Center the modesty panel equidistantly between the table legs and secure with supplied 12 screws.

STEP 6: Secure with supplied 12 screws.

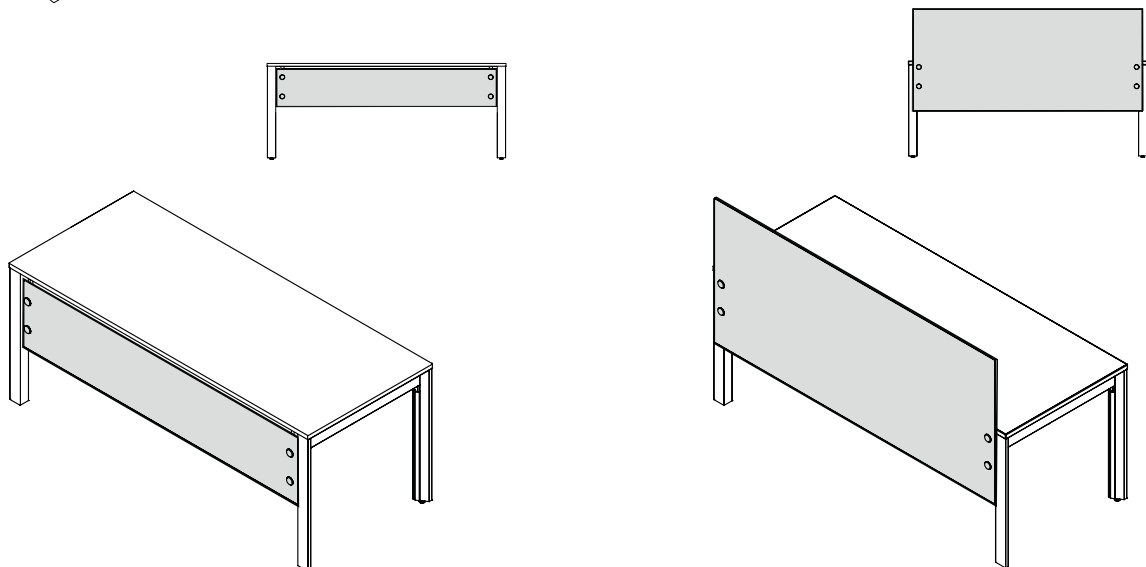
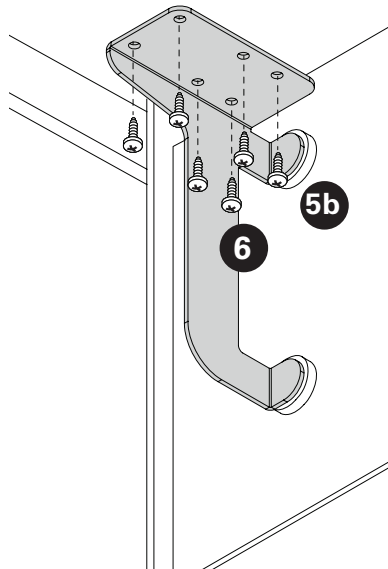
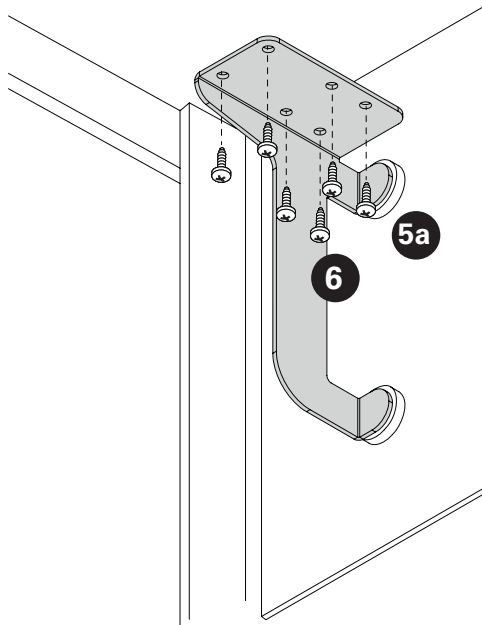
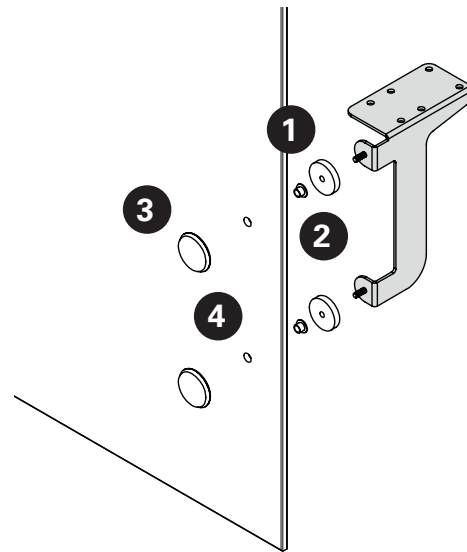

**Glass Perpendicular, End of Run Divider**

- STEP 1: Slide Rubber washer onto threaded studs.
- STEP 2: Slide Spacers on the threaded studs with flange first.
- STEP 3: Position bracket onto the glass and secure with two anodized caps.
- STEP 4: Insert a pin into the hole in the cap and tighten.
- STEP 5: Peel off the protective paper from supplied self adhesive bumpers and attach them along the bottom edge of the divider, placing the center 1/2 from dividers' vertical edge.
- NOTE: Both bumpers must be on the bracket side of the glass.
- STEP 6: Have two installers hold the divider. Align the edges of both brackets with the back edge of the worksurface and center the brackets equidistantly between the table legs.
- STEP 7: Secure with supplied 2 screws in front of and 2 screws behind the leg beam are required for the beam bracket.
- NOTE: 51" and 63" end of run glass dividers and glass modesty panels require 4 brackets.

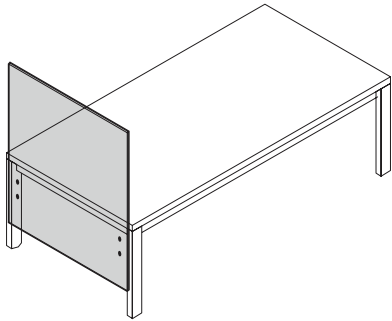
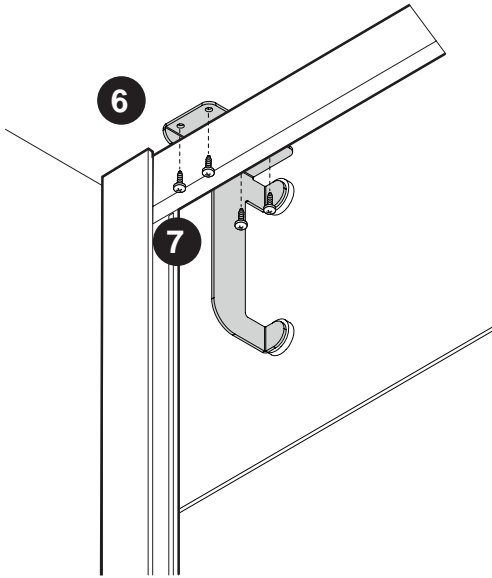
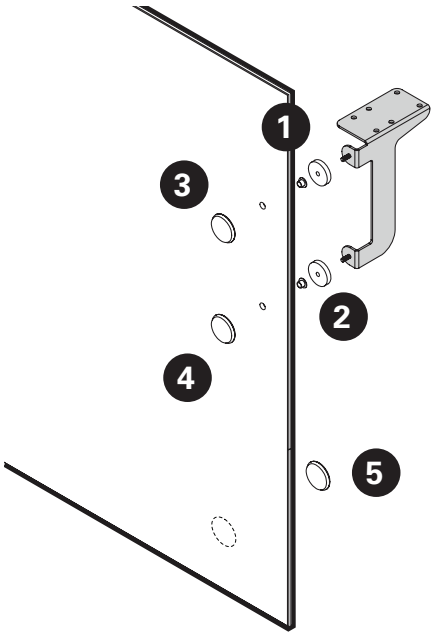

# BRIDGES II INSTALLATION GUIDE

## Perpendicular, Side-to-Side Glass Divider

STEP 1: Press the rear edge of the divider into the bracket.

STEP 2: Slide the divider with the bracket over the rear edge of the worksurface.

STEP 3: If you are installing the glass divider over a seam of two adjacent worksurfaces, press the wide bracket onto the front edge of the glass divider.

STEP 4: If you are installing the glass divider to divide one seamless worksurface or over a seam with recessed leg, then press the narrow front bracket onto the front edge of the glass divider.

STEP 5: Secure all brackets with supplied screws.

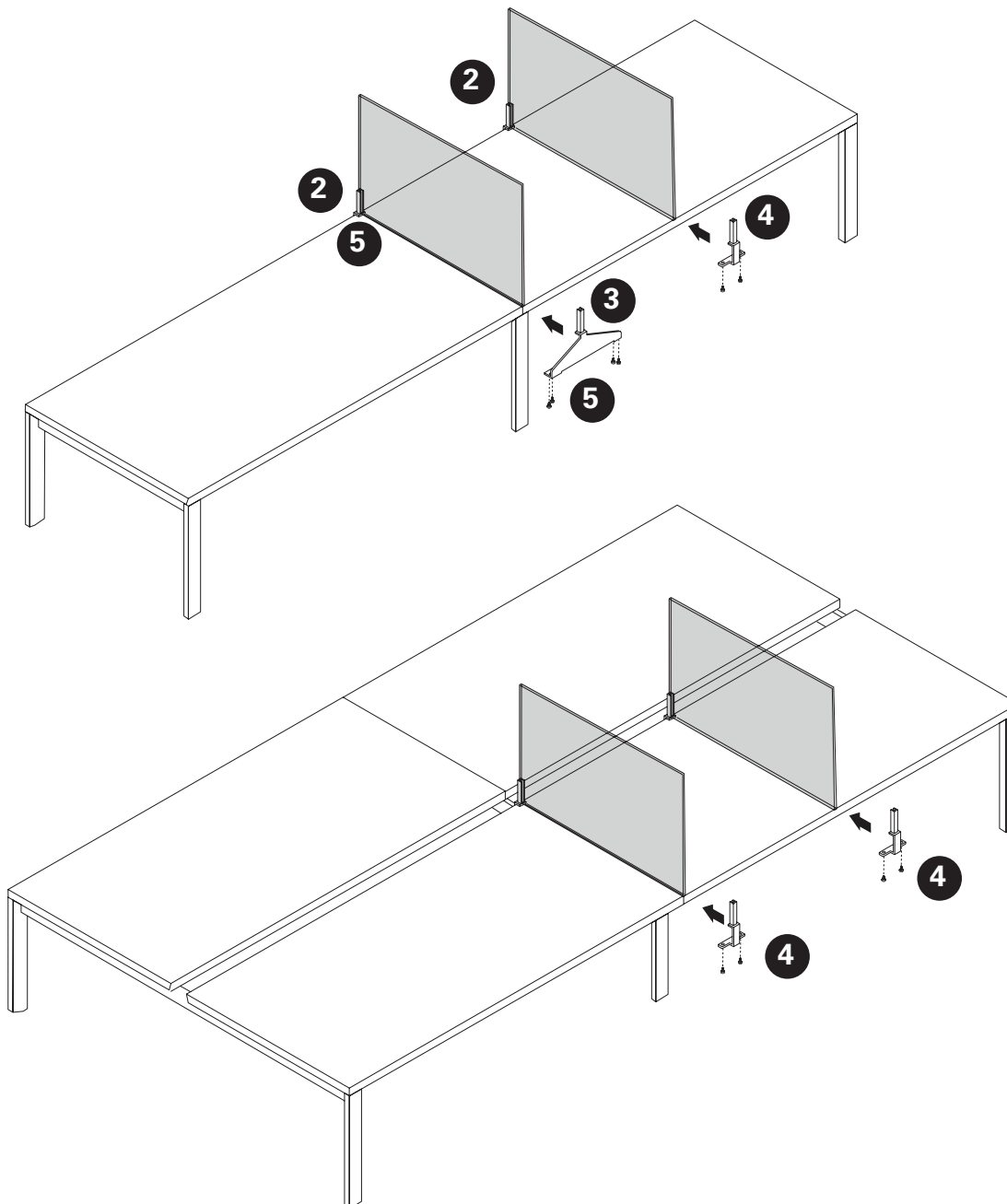
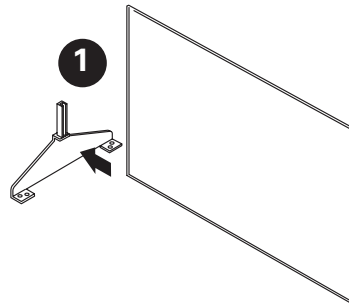

**Elevated Shelves: Parallel / Perpendicular**

Parallel elevated shelf **A** fits over gap between two back-to-back tables. Grommets in its gables accommodate cable passage and Above worksurface power trough.

Establish final location of Perpendicular elevated shelf **B** in accordance with your plans. Position it in place and peel of protective layer from adhesive tape at the bottom of the Perpendicular elevated shelf gables. Apply pressure to ensure that both shelf's gables adhered to the table's worksurfaces.

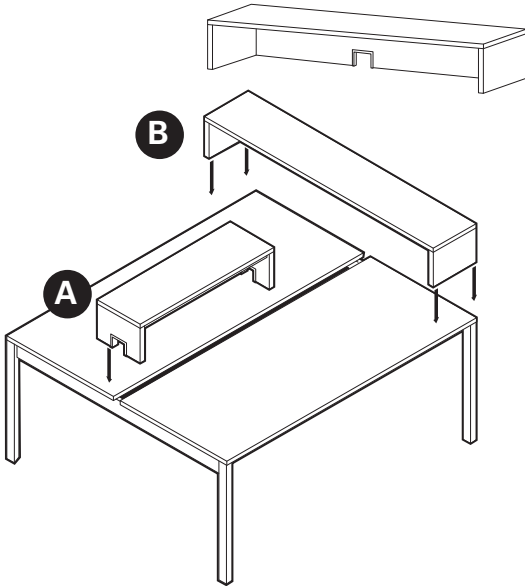

**Shared Credenza and Shared Storage Divider Placement**

Shared credenza has been designed to be placed partially under the table. Worksurface edge should be aligned with the edge of the open **A** compartment as illustrated.

Similarly, Shared storage divider's central partition edge **B** should be aligned with the worksurface as well.

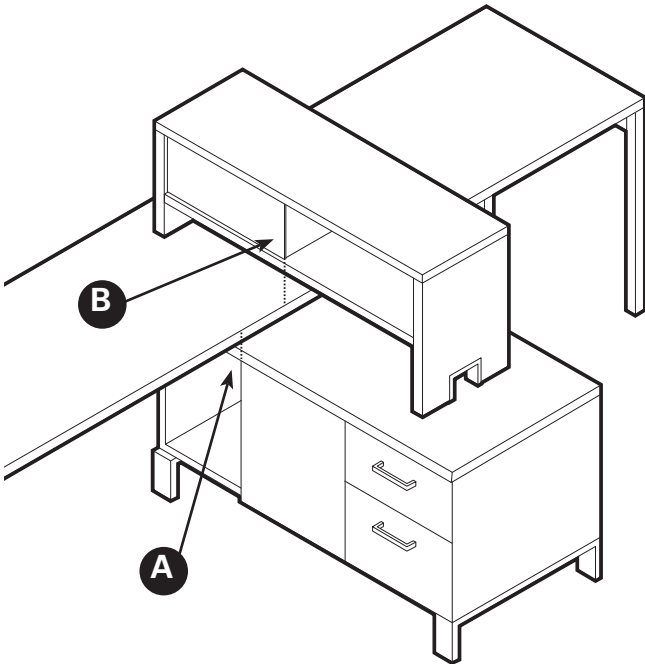



# BRIDGES II INSTALLATION GUIDE

## Table Mounted End Shelf

Note: The table end shelf can only be installed on rectangular legs. Remove vertical cable manager cover from both legs.

STEP 1: Secure hanging brackets to the table end shelf (24" and 30" table end shelves come with two, while 50.5" and 62.5" table end shelves come with four hanging brackets). Slide the brackets through back wall of the table end shelf.

STEP 2: Push the tubular part of the bracket up against the underside of the top and secure the bracket with two supplied nuts.

STEP 3: Align holes in the top part of the bracket with pilot holes and secure with supplied wood screws.

STEP 4: Hang the table end shelf onto the leg horizontal beam, ensure that all brackets are securely seated and the end shelf centered on the leg frame.

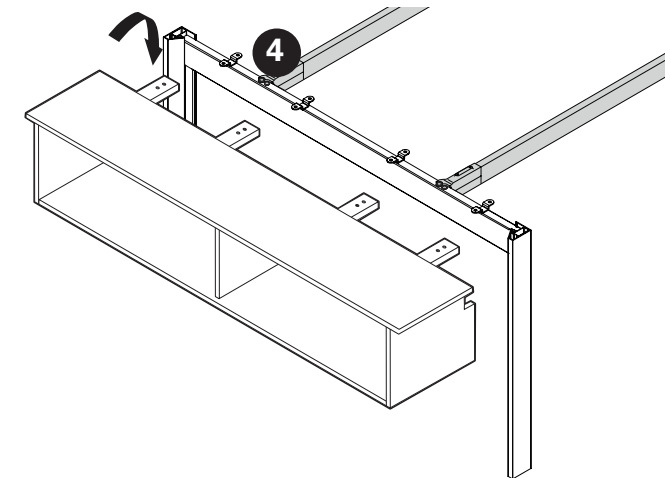
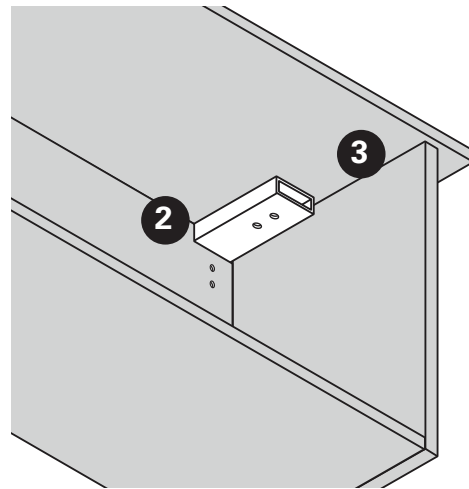
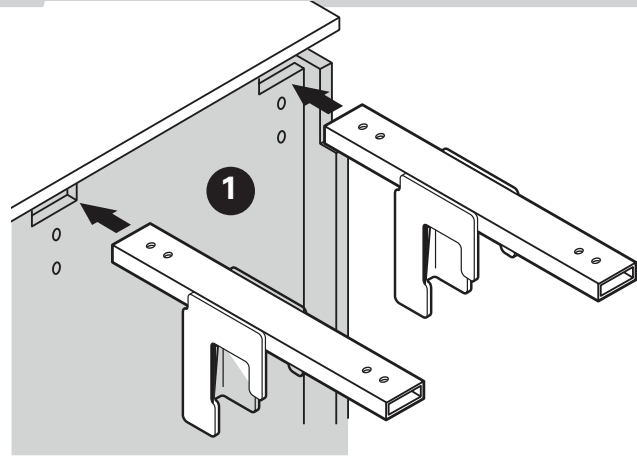

**Table Mounted End Shelf**

STEP 5: Place worksurfaces so that they line up with the external edges of the table end shelf's top. Secure worksurfaces and hanging brackets with supplied screws.

STEP 6: Insert and rotate the gable bottom bracket into the leg, slide it up against the bottom gable edge.

STEP 7: Align the brackets with pre-drilled holes in the gable as illustrated and secure with supplied screws (A).

NOTE: Use supplied machine screws (B) to secure the bracket to the threaded insert in the shelf's bottom.

Trim the vertical cable manager cover and snap it back in place.

STEP 8: Place two angled support brackets over table beams with adjustable clamps. Secure both brackets by driving supplied machine screws into threaded inserts in the back of end table shelf (A).

STEP 9: Ensure that the shelf is level.

STEP 10: Pre-tension the bracket by pushing its end along the beam and worksurface toward the shelf and, while pushing, secure the bracket by driving supplied screws into the bottom of the worksurface.

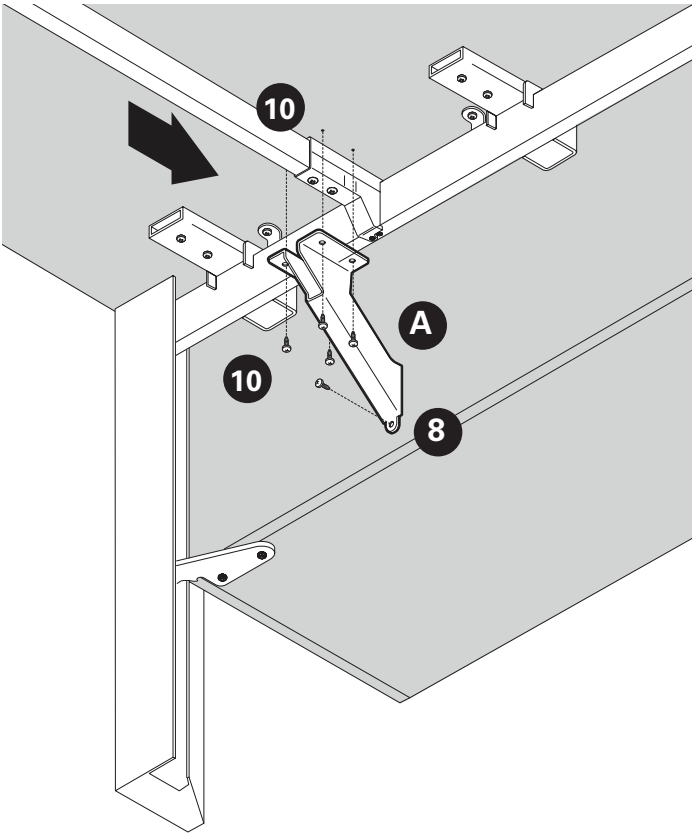
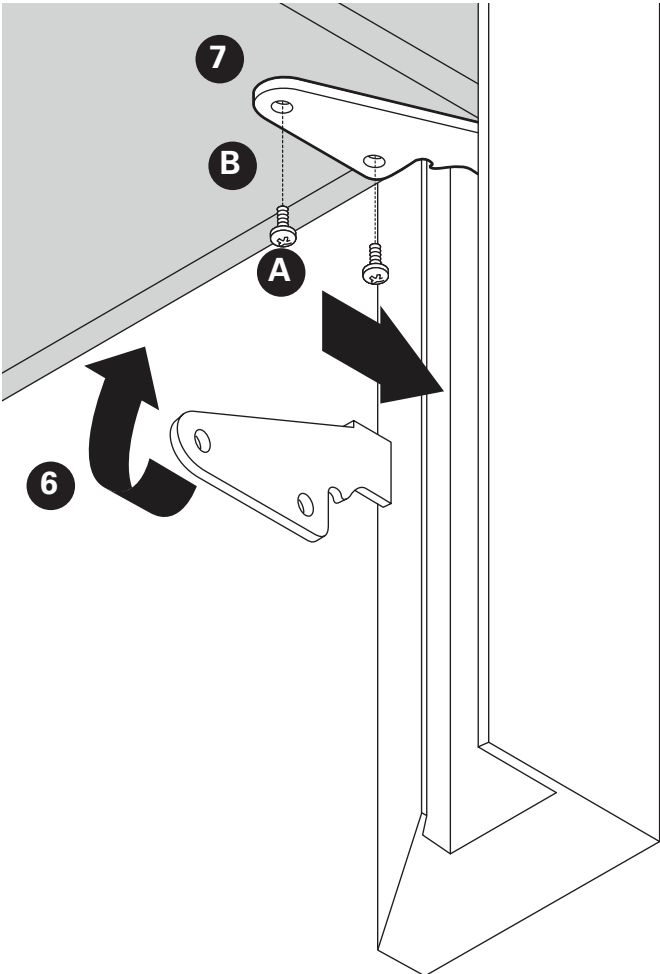
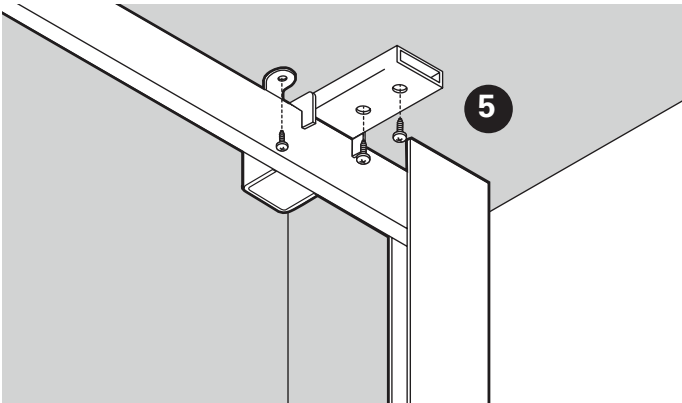

# BRIDGES II INSTALLATION GUIDE

## Storage Tower

To install storage towers in a worksurface-supporting configuration, please see support beam install.

Cable basket - Please see wire basket install under storage spine.

## Storage Spine

Storage units of equal depth can be configured to form longer, interconnected units supported by shared legs. The following steps describe how to convert a single storage leg into a shared one:

Every storage leg is provided with two hole patterns: 3+3 holes positioned closer to the edges of the leg extrusion and 2+2 hole pattern closer to the center of the extrusion.

**STEP 1:** Remove six screws securing the leg to the bottom of the storage unit. (3+3 hole pattern). Three of the six screws are machine thread screws. Store them in a safe place in case you will need to relocate the storage leg again in future. The remaining three long screws will be used.

**STEP 2:** Move the leg so that one half is located under the storage bottom, while the other half remains exposed. Align two of the 2+2 pattern holes with pre-drilled holes in the storage unit gable. Use Allen key to secure the leg with two screws.

**STEP 3:** Remove support leg from the adjacent storage unit, rest the unit on the shared leg, press it against the storage cabinet's side gable. Use Allen key to secure the bottom of the adjacent storage unit with two screws.

Keep the removed leg and fasteners in a safe place for future reconfigurations.

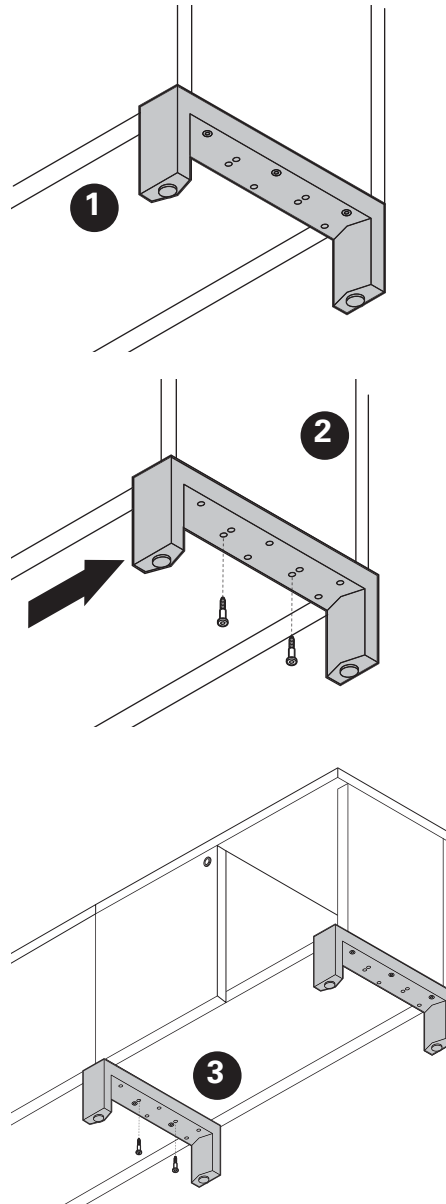

**Storage Cabinet Leg Assembly**

STEP 1: Identify Screws:

(A) 6 pcs. - 1/4 - 20 x 1" Pan Head Screws

(B) 6 pcs - 5/16 - 18 x 1.75 Hex Socket Head Screws

STEP 2: Secure Leg to the storage cabinet with the screws.

NOTE: Drive Hex socket screws into gables.

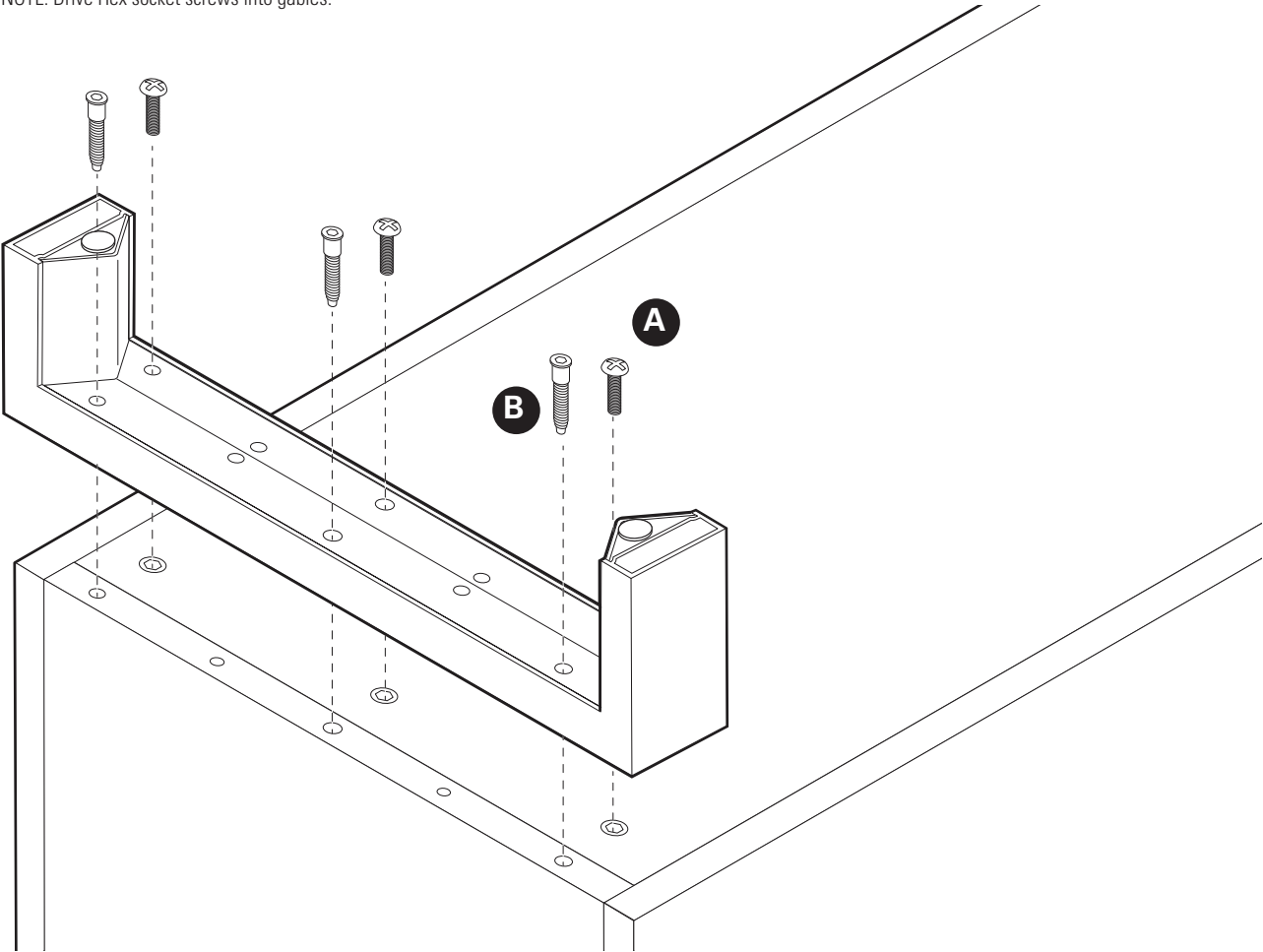

Beam Applications

Legs are connected with supporting beams. There is one beam for a single line of tables while two beams connect back-to-back table structures. Adjustable clamps at either end of the beam can be adjusted to accommodate the following applications in both single table as well as back-to-back table configurations.

STANDARD TABLE BEAM

Single table beam application (1)

Designed to bridge two legs to form support for a single table, or for two back-to-back worksurfaces. Adjustable clamps at either end of the beam are pushed all the way in to allow both table legs to be tucked under the worksurface.



End of run table beam application (2)

Supports one table leg assembly tucked under the worksurface (one adjustable clamp pushed all the way in), while the other table leg assembly can be shared between two adjacent worksurfaces (adjustable clamp pulled out to extend the beam).



Interconnecting table beam application (3)

Supports both table leg assemblies extended to support adjacent worksurfaces on either side. Adjustable clamps at either end of the beam are pushed all the way in to allow both table legs to be tucked under the worksurface. Single table beam application supports single table leg assemblies with legs on both sides tucked under the worksurface.



TELESCOPIC TABLE BEAM (4)

Supports a return connected perpendicularly to a 24" or 30" deep primary worksurface. The Telescopic beam is connected to a single or back-to-back leg on one side and to any worksurface supporting beam on the opposite side. Telescopic beam clamp allows the table leg to be tucked under the worksurface or shared between two adjacent worksurfaces.

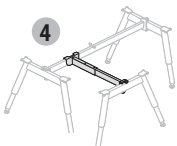

STORAGE TABLE BEAM (5)

The Storage beam is connected to a single or back-to-back leg on one side and to the worksurface on the opposite side - thus saving one leg assembly. Assembly worksurface is connected to storage units with included storage brackets. Storage table beam's flexibility allows for a single table application (with the table leg tucked in under the worksurface) as well as for a double table installation (two adjacent tables supported by a shared leg in the middle and two storage cabinets at the opposite ends).

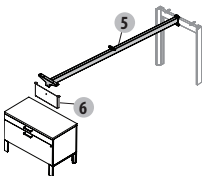

STORAGE TABLE BEAM ADAPTER (6)

Connects to a storage table beam. This assembly allows a worksurface to be supported by a leg on one side and a spine (formed by interconnected storage cabinets) on the opposite side.

# BRIDGES II INSTALLATION GUIDE

## Supporting Structure Round Leg Height Adjustment

Set the legs to desired height.

The inner leg has two threaded holes.

STEP 1: The top threaded hole is typically used to secure legs with levelers.

STEP 2: The lower threaded hole is used for securing legs with casters.

STEP 3: If the desired top surface height is 29" from the floor, for instance, and the table structure is to be on levelers, align top threaded hole in the inner leg (1) with the fourth hole in the table leg (3) as illustrated. When installing legs on casters, align the lower (2) threaded hole in the inner leg with the same fourth hole (3) in the table leg and secure with provided screws.

STEP 4: The height adjustment screws must be only used with the provided, translucent cup/washer.

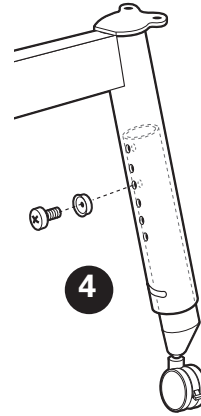
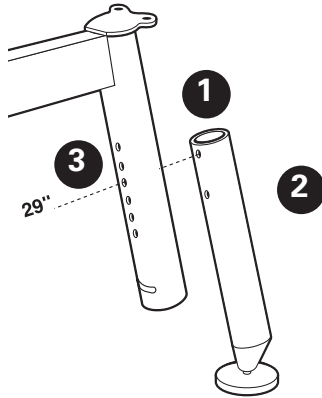

## Supporting Legs and Beams

Table legs are connected to the table supporting beams with die cast aluminum adjustable clamps. The position of these clamps on the beam establishes whether the leg is going to be shared between two adjacent worksurfaces (extended position) or tucked under a worksurface edge (retracted position).

STEP 1: Identify type and length of beam required. A single table, for instance will have both legs tucked under the worksurface and both end brackets, therefore, will be fully contracted. End of run table applications will require one of the beam brackets extended so that the leg it will be connected to could be shared between two adjacent worksurfaces (while the leg on the opposite end of the beam will be tucked under the worksurface at the end of a table run). Similarly, fully extending both beam brackets will allow both table legs to be shared.

STEP 2: In order to adjust beam bracket position, remove both countersunk Allen head screws from the beam clamp assembly. End of supporting beam tube can be seen through the gap between the two beam clamp parts (A). Lines on the bottom part identify two clamp positions. Slide the top part of the clamp along the beam into the desired position, enclose assembly with the bottom clamp part and tighten the countersunk Allen head screws.

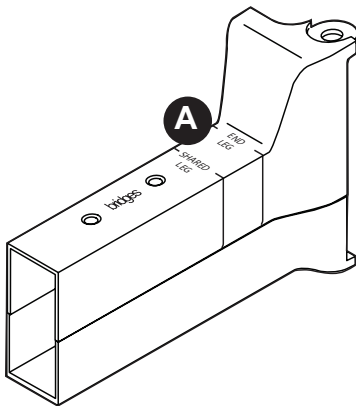
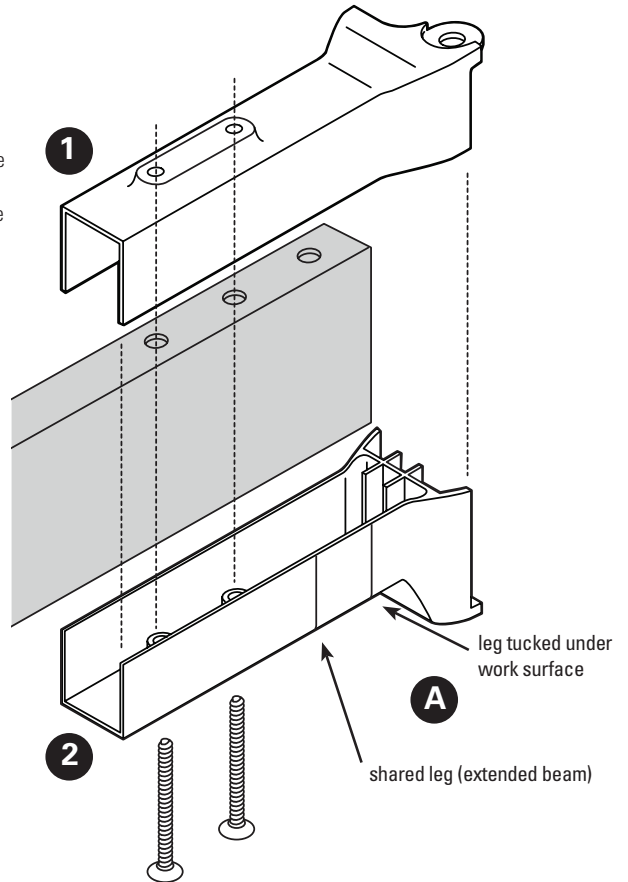

**Supporting Legs and Beams (continued)**

STEP 3: Position beam's end bracket over leg's horizontal, rectangular tube.

STEP 4: Secure top and bottom bracket ends with two supplied screws, but do not tighten the bottom screw.

Level the whole assembly.

STEP 5: Place worksurfaces on top of table structure, align them and interconnect them using flat brackets.

STEP 6: Align this worksurface assembly with legs and secure with screws. Proceed from one corner to the opposite one.

STEP 7: Ensure legs are vertical and tighten the bottom screw.

STEP 8: Adjust nylon set screws in the middle of the beam to flatten the worksurface (if required)

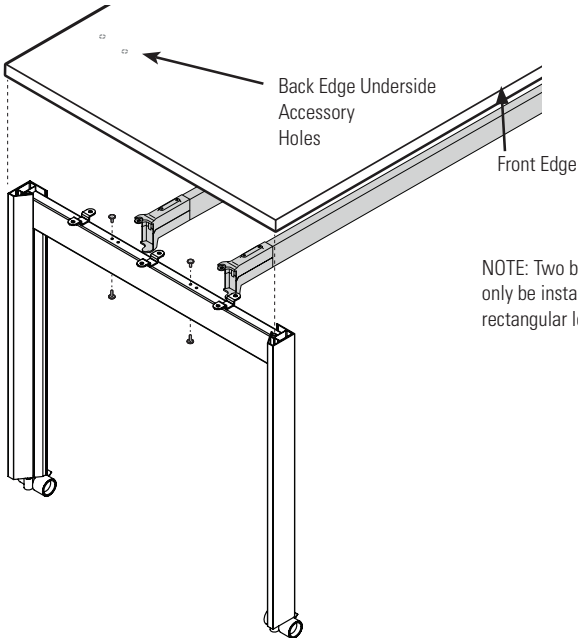
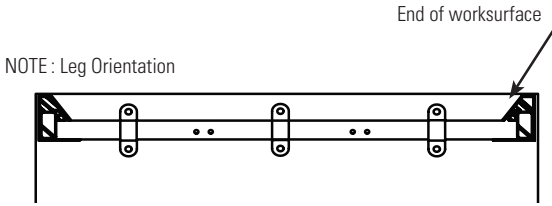
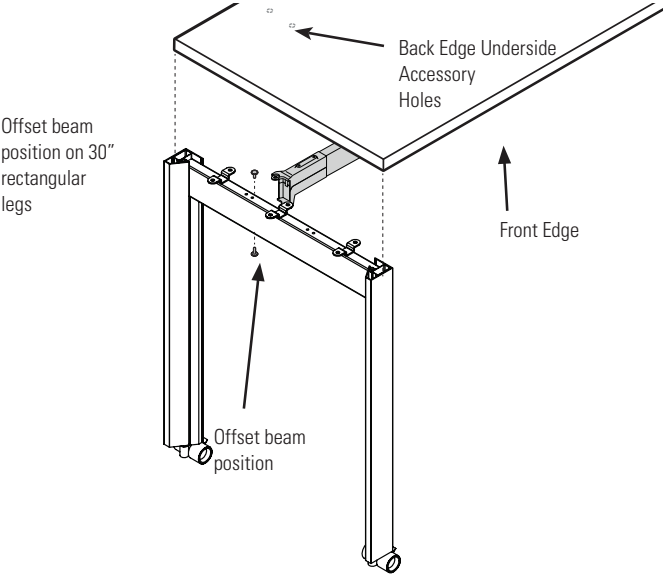
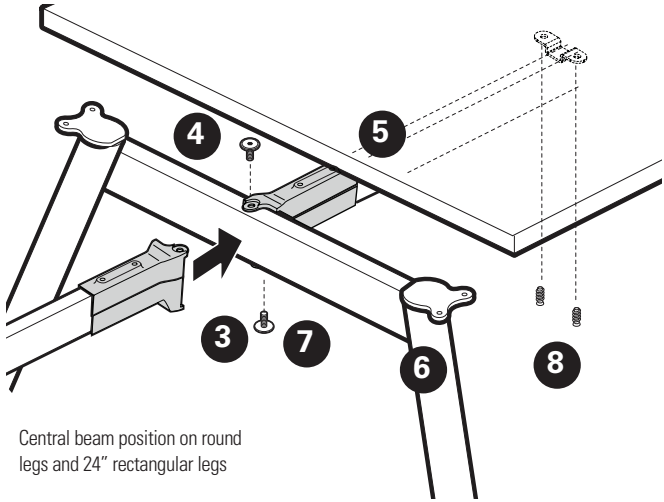

NOTE: Two beams can only be installed on 30" rectangular legs.

# BRIDGES II INSTALLATION GUIDE

## Telescopic Beam

Designed to provide support for worksurfaces perpendicularly connected to a primary table run. The telescopic beam is connected to the leg's horizontal, rectangular tube on one side, while the opposite side is secured off module to the perpendicular, central beam and can be adjusted to accommodate 24" and 30" deep primary worksurfaces.

STEP 1: Position beam's end bracket over leg's horizontal, rectangular tube.

STEP 2: Secure top and bottom bracket ends with two supplied screws.

STEP 3: Adjust the length of the telescopic beam in accordance with the depth of primary worksurface. Completely contracted beam will support perpendicular side table connected to 24" deep primary worksurface on Round and Rectangular legs. Middle position is intended to support perpendicular side table connected to 30" deep primary worksurface on Round legs. Fully extended telescopic beams support perpendicular side table connected to 30" deep primary worksurface on Rectangular legs.

STEP 4: Position end bracket of the telescopic beam over the primary, perpendicular beam. Level the whole assembly.

STEP 5: Install primary worksurface.

STEP 6: Secure the secondary worksurface to legs first.

STEP 7: Adjust the secondary worksurface/telescopic beam position.

STEP 8: Secure the worksurfaces with flat brackets.

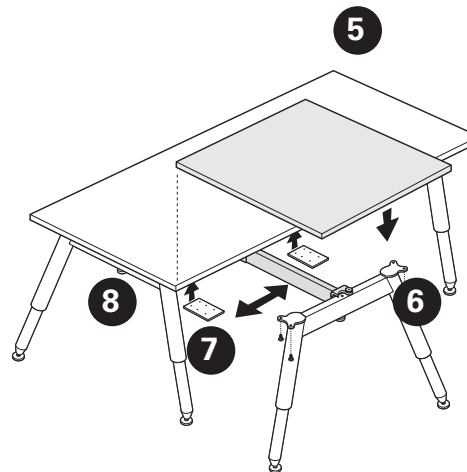
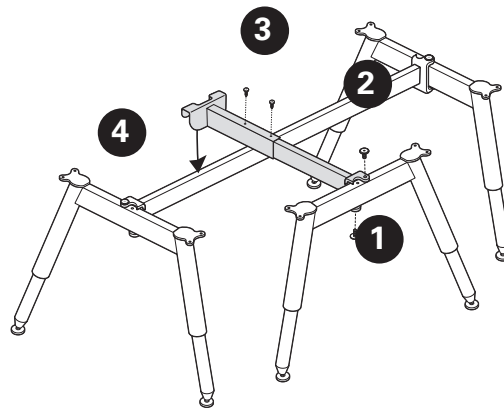



**120° Leg**

The integrated 120° beam bracket allows for the beam to be mounted in two positions:  
A) end of run leg placement  
B) shared leg placement

Identify the desired leg position (A or B)

- STEP 1: Align two mounting holes in beam with two holes in the integrated 120° beam bracket. Position beam's end bracket over leg's horizontal, rectangular tube.
- STEP 2: Secure both beams to the integrated 120° beam bracket with four supplied screws.
- STEP 3: Position beam's end bracket over leg's horizontal rectangular tube.
- STEP 4: Secure top and bottom bracket ends with two supplied screws.
- STEP 5: Level the whole assembly.
- STEP 6: Install worksurfaces and secure with supplied screws by proceeding from the central, 120° leg to the outside of the assembly in both directions.

NOTE: 24" deep worksurfaces are mounted centrally on top of the table structure. 30" deep worksurfaces are mounted off center, with a longer overhang facing the user.

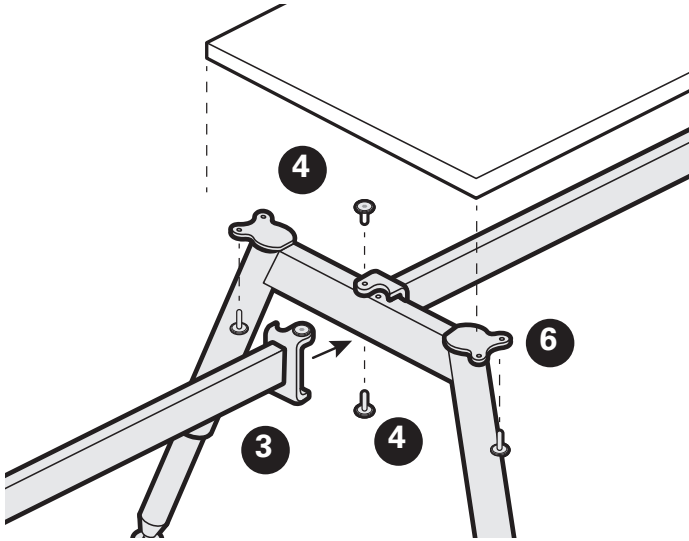
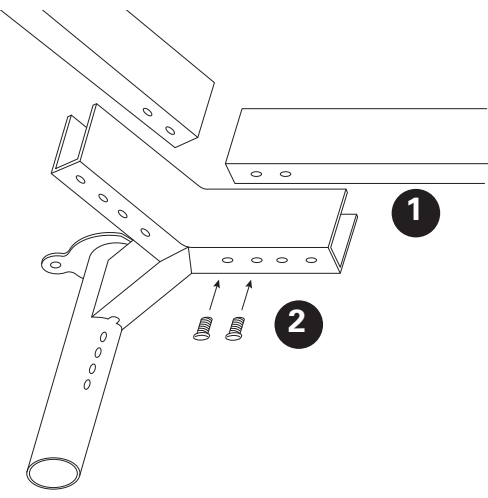
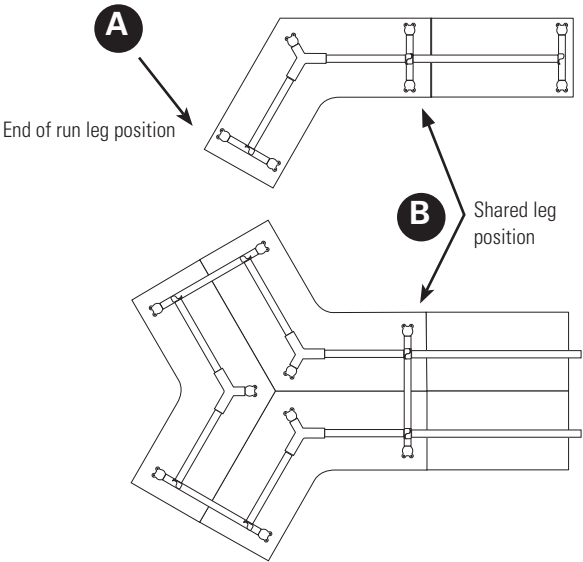

# BRIDGES II INSTALLATION GUIDE

## Storage Table Beam

Storage table beam's flexibility allows for a single table application (with the table leg tucked in under the worksurface) as well as for a double table installation (two adjacent tables supported by a shared leg in the middle (A) and two storage cabinets at the opposite ends).

- STEP 1: Position beam's end bracket over leg's horizontal, rectangular tube. Use Allen keys to secure top and bottom bracket ends with two supplied screws. Level the whole assembly.
- STEP 2: Turn the worksurface upside down on a smooth surface and secure it to the leg/beam subassembly with supplied screws.
- STEP 3: Mount two L brackets to the side of Storage tower. Drive two supplied machine screws through the brackets into threaded inserts embedded in the storage tower side panel.
- STEP 4: Place the Storage tower in its final location and position the leg/beam/worksurface assembly so that the worksurface rests on the installed L brackets. Ensure that the worksurface and the tower are aligned. Secure the worksurface to the L brackets with supplied screws.

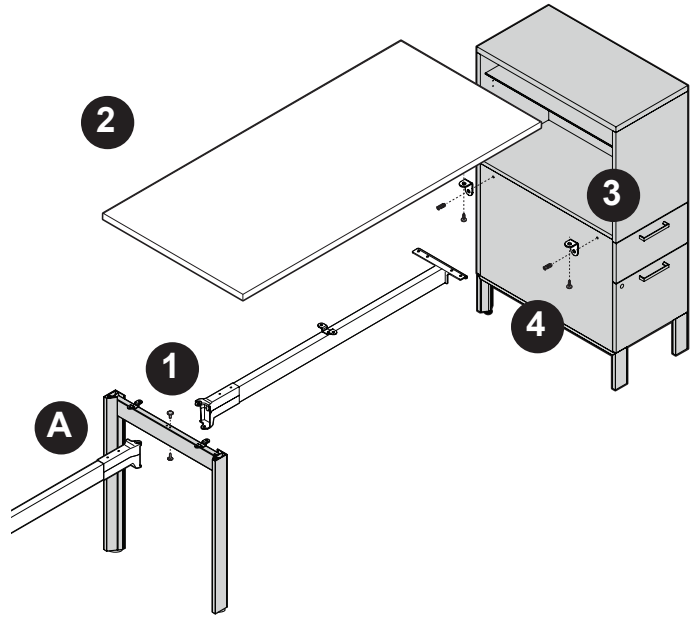

## Spine / Storage Table Beam Adapter

Storage table beam adapter allows a worksurface to be supported by a leg on one side and a spine storage cabinet on the opposite side. A typical Storage spine is formed by series of interconnected 21" or 25" high storage cabinets of corresponding depth.

The Storage beam is connected to a single or back-to-back leg on one side and to the worksurface on the opposite side - thus saving one leg assembly.

The 21" or 25" adapters provide structural support - acting as supports between top of the storage cabinet spine and the bottom of perpendicular worksurfaces.

The flexible leg/beam/adapter assembly arrangement allows the leg to be tucked in under the worksurface or to be shared by two adjacent worksurfaces. Included hardware connects the adapter to the worksurface and to the storage table beam.

- STEP 1: Position beam's end bracket over leg's horizontal, rectangular tube. Use Allen keys to secure top and bottom bracket ends with two supplied screws.
- STEP 2: Attach Spine / Storage table beam adapter to the Storage table beam. Use Allen key and the supplied screw to secure.
- STEP 3: Turn the worksurface upside down on a smooth surface and secure it to the leg/beam/adapter subassembly with supplied screws.
- STEP 4: Rest the leg/beam/adapter/worksurface assembly on top of the storage spine. Adjust the desired position. Secure the assembly by driving two supplied screws through the bottom of the adapter, into the top of the storage cabinet.

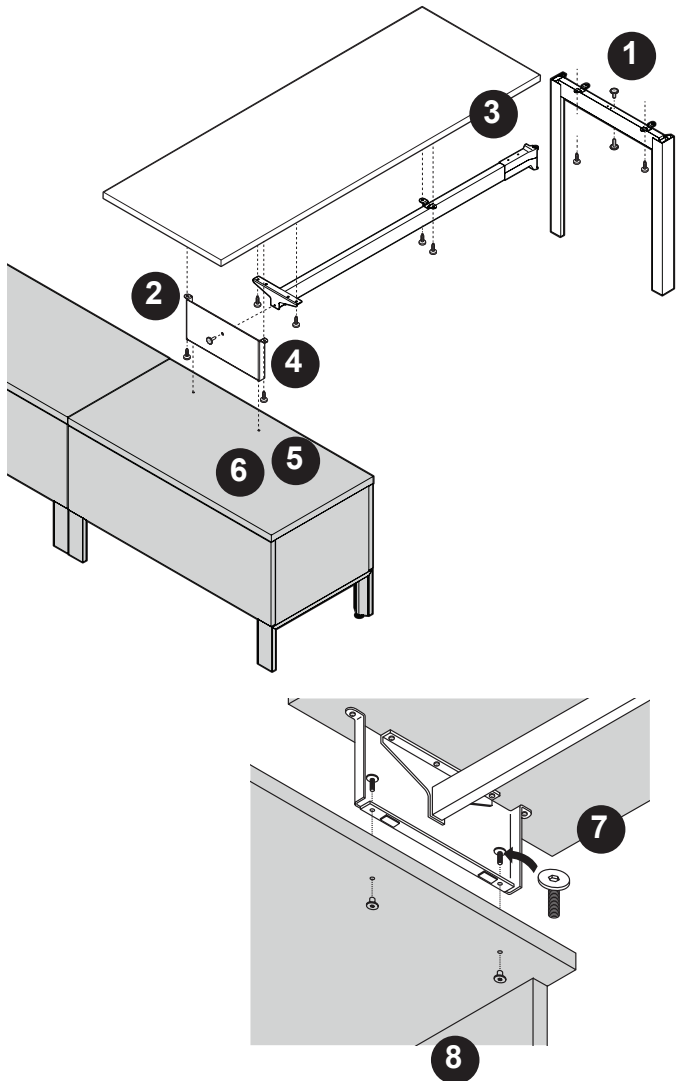

Sliding Return

NOTE:

Round legs:

Sliding Return can be installed anywhere along the front edge of worksurface supported by round legs.

Rectangular legs:

Sliding Return can be installed along the front edge of worksurface between Rectangular legs.

Sliding return can be installed under a seam of two adjacent worksurfaces supported by recessed, 3/4" back-to-back leg.

Ensure that back-to-back table installation is complete, level and structurally sound. Installation of Sliding Rail requires a special degree of accuracy of worksurface alignment. Failure to do so may result in binding of the sliding mechanism on the Sliding Rail.

Establish range of the Sliding Return.

- STEP 1: Mark a line 3" in from (and parallel with) the front edge of worksurface.
- STEP 2: Position the Sliding Rail and secure it with supplied screws. Always proceed from the second hole, leaving the first hole for installation of the Rail stop.

NOTE: The pair of screws provided to secure the rubber rail stops at either end of the rail are longer than the screws for securing the rail to the worksurface. Do not use these longer screws to secure the rail as the screws may penetrate through the top of the worksurface.

STEP 3: Secure leg support bracket to a leg frame with supplied machine screws (wide flat allen head).

STEP 4: Place the Sliding Return worksurface upside down on a clean surface. Secure the leg assembly to the worksurface with supplied wood screws. Ensure that the legs are set to the same height as the legs supporting the rest of the table installation.

STEP 5: Place eight supplied rubber spacers over pre-drilled holes. If you are converting an existing Return worksurface to a Sliding Return, mark a line 1" in from (and parallel with) the edge of the Return worksurface.

STEP 6: Align supporting brackets with rubber spacers / pre-drilled holes (or the marked line) and secure both brackets with supplied wood screws.

NOTE: In order to ensure a smooth sliding action, both brackets must be perfectly perpendicular to the edge of the return worksurface.

STEP 7: Slide the two glide blocks with bushings carefully onto the Rail as illustrated.

STEP 8: This step requires two people:  
 While the leg supported side of the Return rests on the floor have an assistant position supporting brackets under sliding glide blocks, align the holes and gently drive in two machine screws (metric M6 as provided). Do not tighten. In the same manner secure the second bracket to the second glide block and test smoothness of the slide. Carefully tighten all four metric screws while repeatedly testing smoothness of the slide. If the return binds on the Sliding Rail, then your support bracket(s) are not perpendicular to the rail - causing the glide blocks to jam.

STEP 9: Secure rail stops to both ends of the rail with supplied (longer) screws to prevent disengagement.

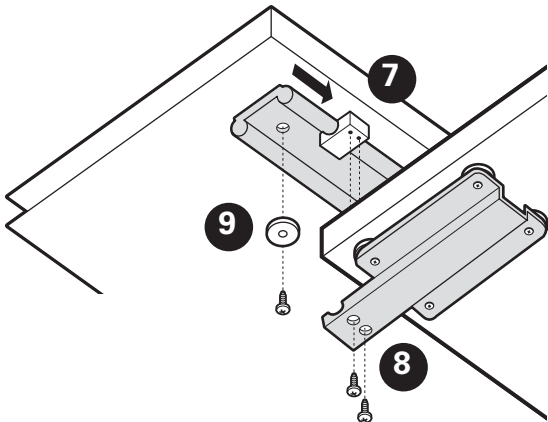
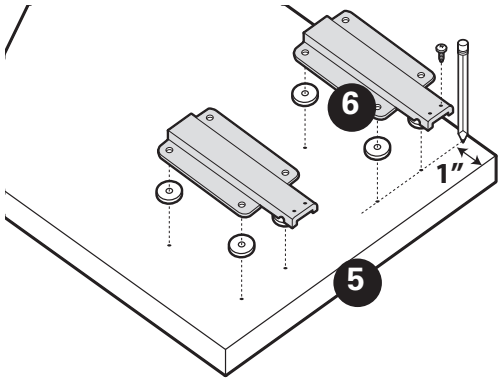
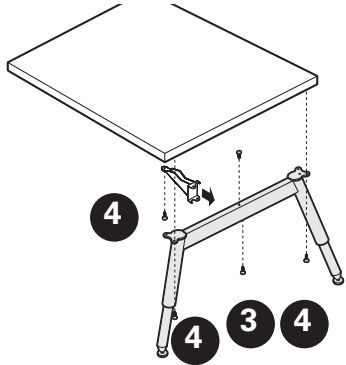
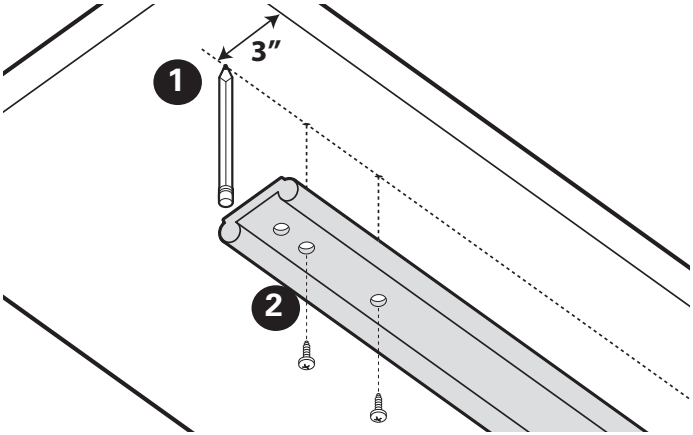

# BRIDGES II INSTALLATION GUIDE

## Round Table Supports

Round table structure consists of one main leg and two individual legs.

STEP 1: Put round top upside down on a clean flat surface.

STEP 2: Position each individual leg.

STEP 3: Secure the legs with supplied screws. Level the whole assembly.

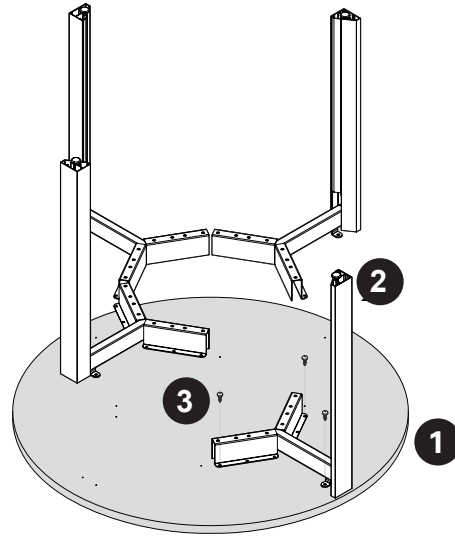

## Glide Tray Adapter Assembly

Both machine screws and wood screws are provided with each pair of brackets.

Assembly:

STEP 1: Position the brackets (as shown) on the flat side of the Glide Track to align the selected holes.

STEP 2: Attach the brackets to the Glide Track using the supplied machine screws. Push the screws through the holes in the Glide Track and thread them into the Nut Inserts.

STEP 3: Position the track and bracket assembly where desired on the underside of the worksurface and fix in place using the four supplied wood screws.

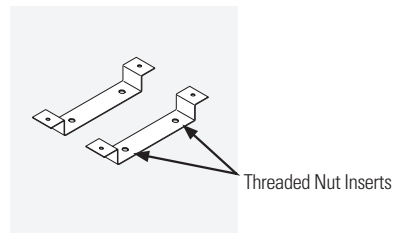

**Caution: The wood screws are designed to be used with 1" or thicker worksurfaces. Check to make sure the screws will not penetrate through the top of the surface.**

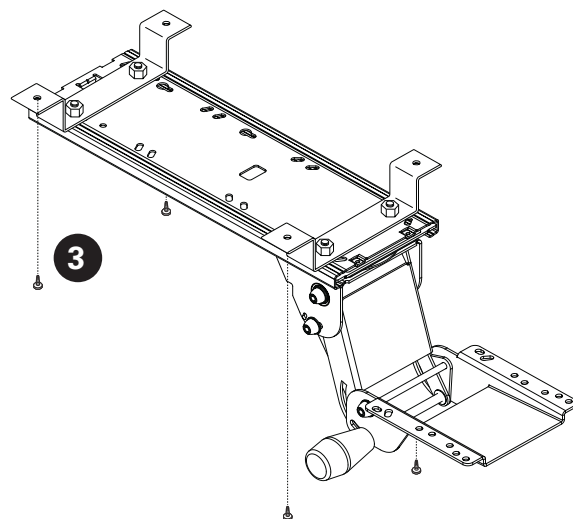
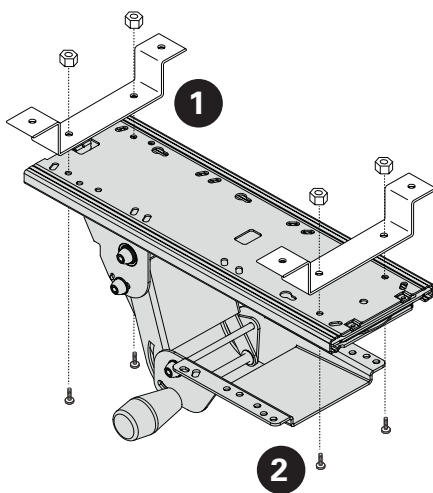

Power, Data and Cable Management

Overview

- Wire basket
- Above worksurface back-to-back power trough with base feed and ceiling feed
- Below worksurface back-to-back power trough with base feed
- Ceiling feed
- Below worksurface single-sided power trough with base feed
- Storage power box

Power Delivery / Cable Management

At the basic level, table and floor based office equipment is serviced by a wall or floor power supply. As the operation grows, there might be a need to organize excessive cable clutter.

**Wire basket (1)** connects to the underside of worksurfaces with sprig brackets and cables are simply dropped and coiled into them.

**Cable Snake(2)** installed in proximity of floor monument to manage vertical cable clutter.

Table clamped, single circuit **Desk Top Power Data Modules (3)** deliver services to desk height, while tapping into wall or floor power supply. Again, the excessive cables can be managed with Cable Trays.

**Ceiling pole BRTCPP (4)** manages power and data cables between ceiling and above or below worksurface power troughs.

**Above and Below Worksurface Power/Data Troughs (5)** can be installed between back-to-back tables for extended below and above desk height power / data distribution. - 8 wire, 4-circuit system.

**Single Sided Power/Data Troughs (6)** can be installed to the underside of a single table.

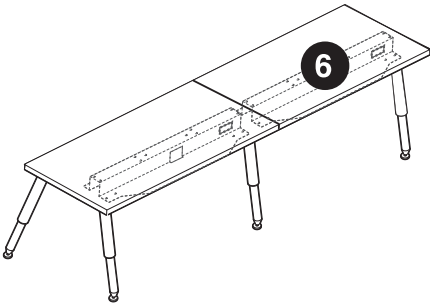
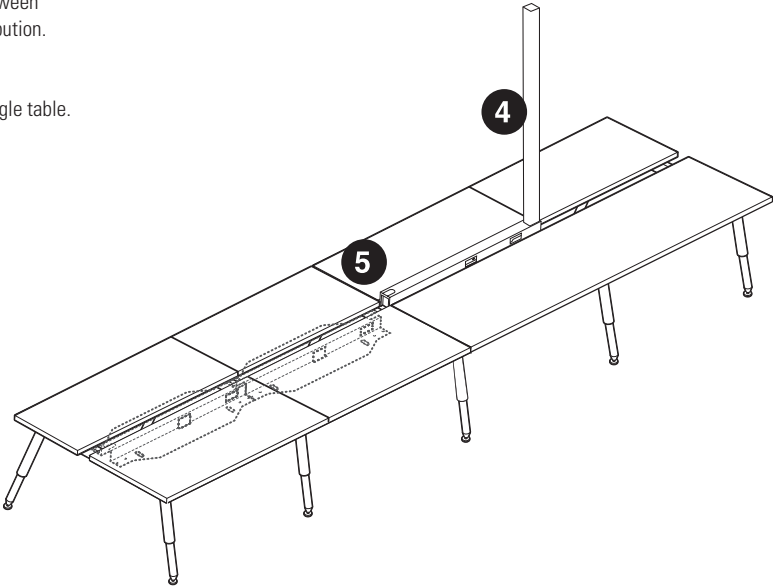
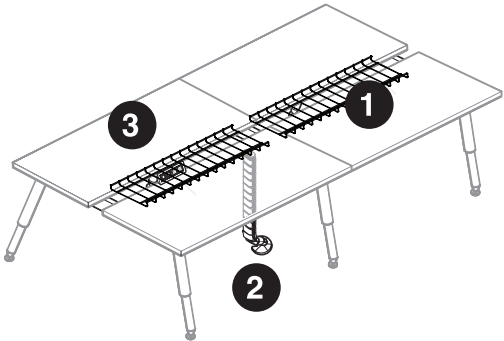

**Storage power/data box BRTVCM (7)** attaches to storage units and provides access to one duplex/data terminal on top storage surface. Integrated single circuit module can be plugged to floor monument under the storage or to a wall outlet.

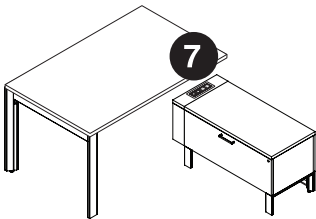

# BRIDGES II INSTALLATION GUIDE

## Wire Basket

### Wire Basket

8" wide basket manages cable excess under single and back-to-back worksurfaces, as well as under storage cabinets. It is suspended on four spring steel brackets so it can be easily unclipped to rearrange cable connections from below the worksurface or below storage units.

Wire baskets are available in incremental sizes, usually about 8" shorter than the intended worksurface / storage span.

STEP 1: Identify the correct basket length. Attach supplied spring brackets on the basket as illustrated so that the hooks point inward. Center the basket below worksurface.

STEP 2: Secure by driving supplied screws through the four brackets into the worksurface.

**Storage cabinet installation:** bottoms of storage cabinets are provided with pre-drilled holes. Attach supplied spring brackets on the basket so that the hooks point inward. Secure the baskets by driving supplied screws through the four brackets into the storage cabinet's bottom.

Long Wire Baskets can span under several storage cabinets. As a general rule, specify Cable Basket min. 8" shorter than the storage cabinet spine assembly.

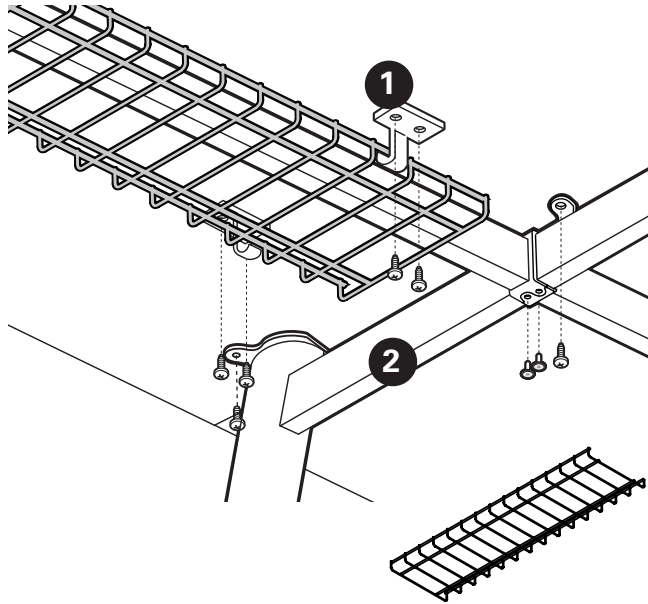

## Below Worksurface Power Trough

**NOTE:** Install dividers, storage and table top accessories prior to proceeding with the installation of below surface power trough.

### A) SUPPORTING STRUCTURE

Identify length and location of required Power Troughs and position them in accordance with lay-out plans. Install brackets on Power Troughs. Make sure that all Power Troughs are securely connected before proceeding with installation of electrical components.

### B) ELECTRIC COMPONENTS

Identify type and location of required electrical components and position them in accordance with lay-out plans. Secure Power Feed to the Power Trough brackets (ensure that the liquid tight whip is long enough to reach the power source / floor monument). Proceed with connecting Power Distribution Assemblies and Jumper Harnesses on the ground, just below their future location. Install Duplex Receptacles as specified. Secure interconnected electrical components to Power Trough.

### C) DATA/COMMUNICATION

Arrange cables below their future location into bundles under the tables. Install cable terminals and snap Terminal Plates into the openings in the middle of Power Trough. Proceed from one side of the table assembly, lift cable bundles and secure them to the Power Trough with extruded Data Cable Manager.

### D) CONNECT TO THE BUILDING POWER SUPPLY

It is recommended that the connection to the building power supply be made under the supervision of a licensed electrician and according to applicable codes and regulations. Connection to the building power supply must be done by a licensed electrician. Do not connect or disconnect components while the system is under load. Disconnect the main power before servicing or reconfiguration.

### E) WALK THROUGH / INSTALLATION INSPECTION

## Below Worksurface Power Trough Installation

STEP 1: Install four brackets (two pairs of left and right brackets are required). Below worksurface Power troughs are provided with 4 pairs of mounting holes to accommodate the brackets at various table leg positions.

Two back-to-back tables use narrower supporting beams and the legs on both sides are, therefore, inset below worksurfaces. To fit the Trough and brackets into this narrower space, use a pair of mounting holes "B - B" to secure below worksurface Power Trough to a single assembly of two back-to-back tables.

A back-to-back table assembly at the beginning of a multiple table run employs slightly longer supporting beams to accommodate the legs on the 'start-of-a-run' side to be inset below worksurfaces, and the shared leg to be right below the seam of two adjacent worksurfaces. Use a pair of mounting holes "B" to secure brackets to the Power Trough on the 'start-of-a-run' side, use the pair of mounting holes "A" to secure brackets to the Power Trough on the 'shared' leg side.

A back-to-back table assembly in the middle of a multiple table run employs the longest, interconnecting supporting beams - placing shared legs right under the seams of adjacent worksurfaces on both sides. Use mounting holes "A" on both sides to secure brackets to the Power Trough.

Position the Power Trough over the brackets so that threaded studs on the brackets protrude through the holes in the Power Trough. Secure brackets with supplied thumb nuts. NOTE: Ensure that trough ends are equidistant from worksurface ends.

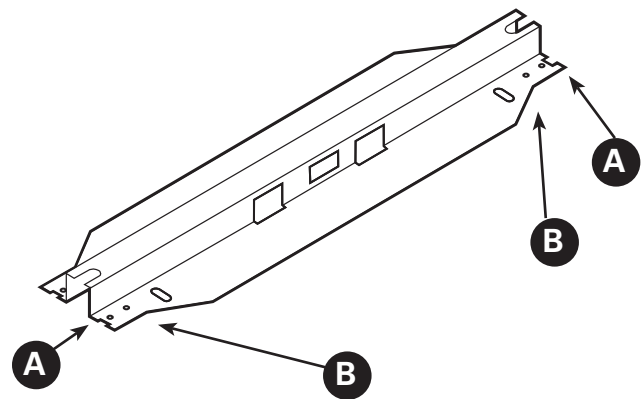

**Below Worksurface Power Trough Installation**

STEP 2: Engage Trough's brackets with the leg's horizontal beam. Ensure that tab "D" fits over the leg beam. Use tab "E" to locate the bracket against the leg worksurface bracket as illustrated.

STEP 3: Secure each bracket by driving supplied screws through tab "C" into the bottom of the worksurface.

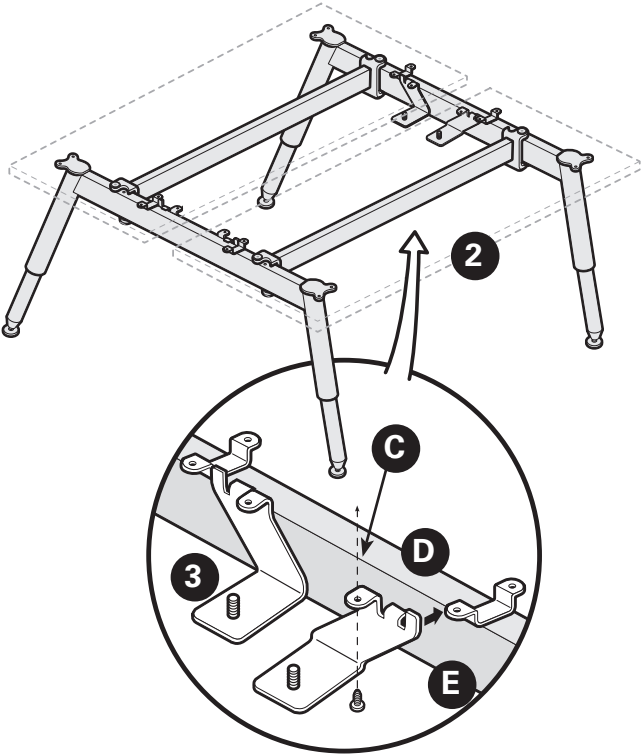

**Power Trough - 120° Installation**

Installation of 120° Power Troughs and Below worksurface Power Troughs on a worksurface supported by storage Towers.

120° Power Troughs and Power Troughs on a worksurface supported by storage Towers are secured to tables with two types of brackets: the standard trough-mounting brackets on one side (the same, above described rules apply: (A) position for shared application; (B) position for end of a run application) and narrow "Z" brackets securing the opposite side of the Power Troughs in the proximity of the 120° 'corner' leg or in the proximity of Storage Tower.

STEP 1: Install trough brackets

STEP 2: Preassemble "Z" brackets and power Troughs: Thread the threaded stud through the Power Trough as illustrated. (Notch in the front edge of the Power Trough prevents the "Z" bracket from rotating).

STEP 3: Engage Trough's brackets with the leg's horizontal beam. Ensure that tab "A" fits over the leg beam. Use tab "B" to locate the bracket against the leg worksurface bracket as illustrated.

STEP 4: Secure the Trough by driving supplied screws through tab "C" and through "Z" brackets into the bottom of worksurfaces.

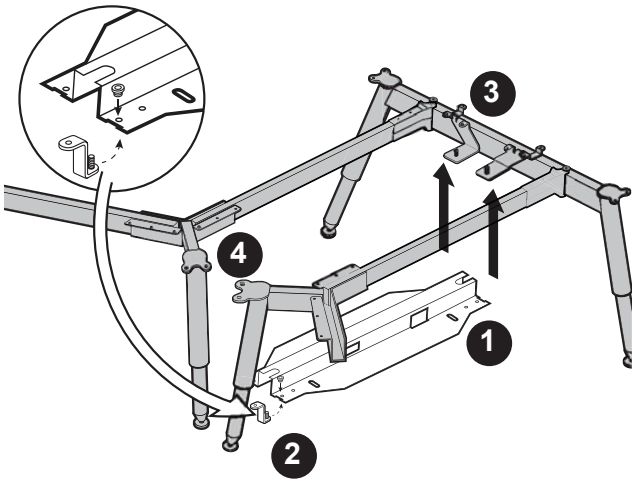

# BRIDGES II INSTALLATION GUIDE

## Power Trough Electric Components - Below Worksurface Trough Base Feed

Identify type and location of required electric components and position them in accordance with lay-out plans.

STEP 1: Secure Power Feed to the Power Trough brackets (ensure that the liquid tight whip is long enough to reach the power source / floor monument).

STEP 2: Lift the Power Trough on one side and rest the Power Feed mounting bracket on top of the Power Trough brackets.

STEP 3: Lower the Power Trough so that the Power Feed bracket is sandwiched between the Power Trough and Power Trough supporting brackets; ensure that threaded studs protrude through the holes in the Power Trough.

STEP 4: Secure all Power Troughs with supplied knurled thumb nuts.

STEP 5: Connect Power Distribution Housings and Jumper Harnesses on the ground, just below their future location.

NOTE: There is an arrow and a letter "N" on each Power Distribution Housing and on every Jumper Harness referring to the correct position in relation to each other.

STEP 6: Install Duplex Receptacles as illustrated, with circuit numbers in accordance with the electrical plans.

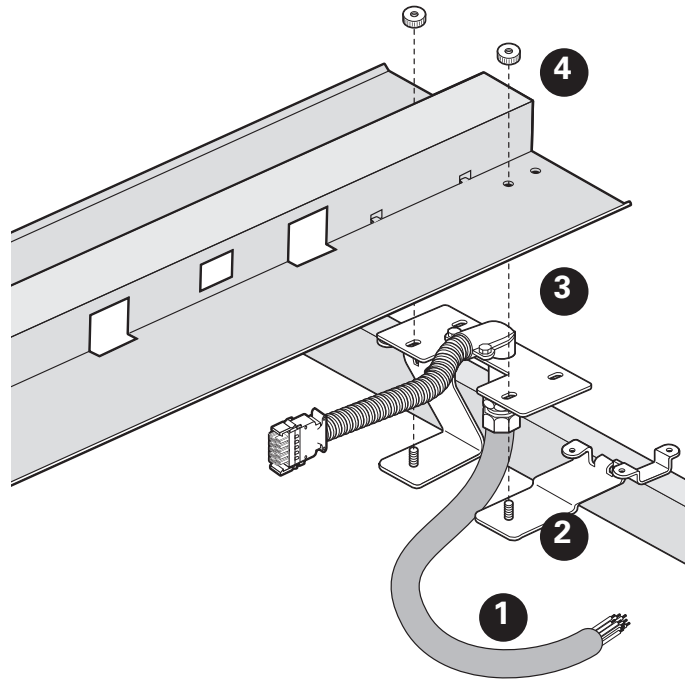
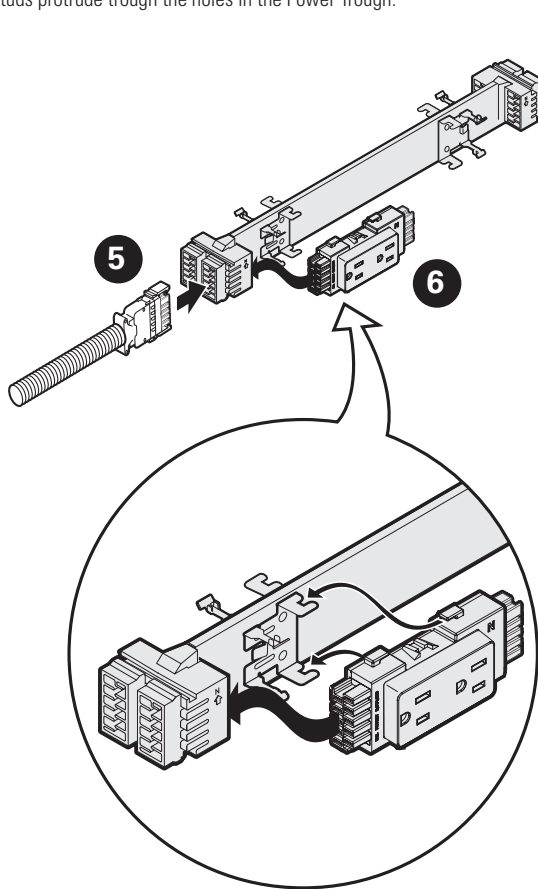



**Power Trough Electric Components : Continued**

STEP 7: Secure interconnected Electrical Components to Power Troughs: Proceed from the Power Feed by connecting its harness to the Power Distribution Housing.  
NOTE: There is an arrow and a letter "N" on each Power Distribution Housing and every Power Feed referring to the correct position in relation to each other.

STEP 8: Insert assembled Electrical Components into the Power Trough from the bottom. Ensure that all four Duplex Receptacles are located in their designated openings.

STEP 9: Insert Power Distribution Housing Lock into the gap between Power Trough and the bottom of the Duplex Receptacle.

STEP 10: Slide back to engage the opposite end as illustrated.

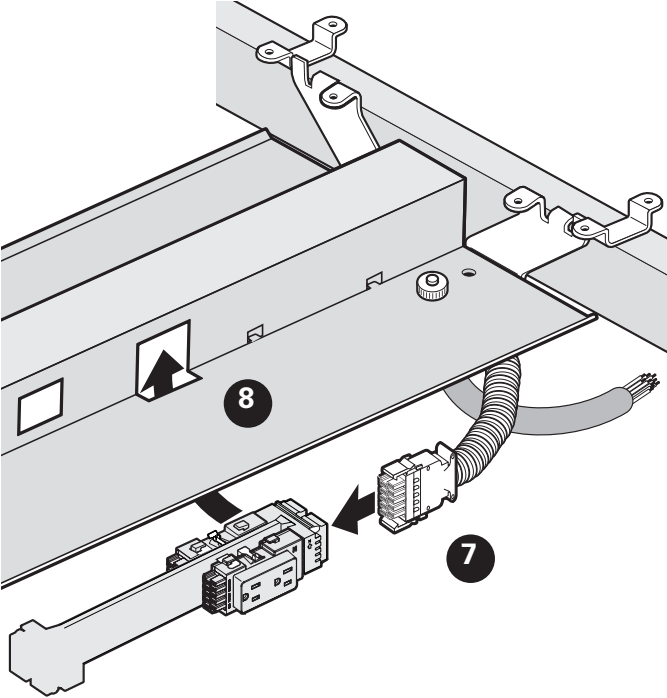

Organize data/communication cables on the ground, just below their future location.

STEP 12: Thread cable through data/communication opening (located in the middle of each Power Trough). Connect terminals and snap terminal plate into data/communication opening.

STEP 13: Capture cable bundles in the extruded Data Cable Manager trough

STEP 14: Snap Data Cable Manager Trough into the bottom of Power Trough. Ensure that data/communication troughs are securely engaged with all tabs at the bottom of Power Troughs. (Refer to actual part).

STEP 11: Repeat steps 9 and 10 under the opposite Duplex Receptacle. Proceed to the opposite end of Power Distribution Housing.  
Ensure that all electrical components are interconnected and secured to Power Troughs.  
Connect Power Feed to the building power supply.

**NOTE: There must be only one power feed entry into each cluster of harnesses. WARNING! It is recommended that installation of the wiring system be made under the supervision of a licensed electrician in accordance with applicable codes and regulations. Connection to the building power supply must be done by a licensed electrician. Do not connect or disconnect components while the system is under load. Disconnect the main power before servicing or reconfiguration.**

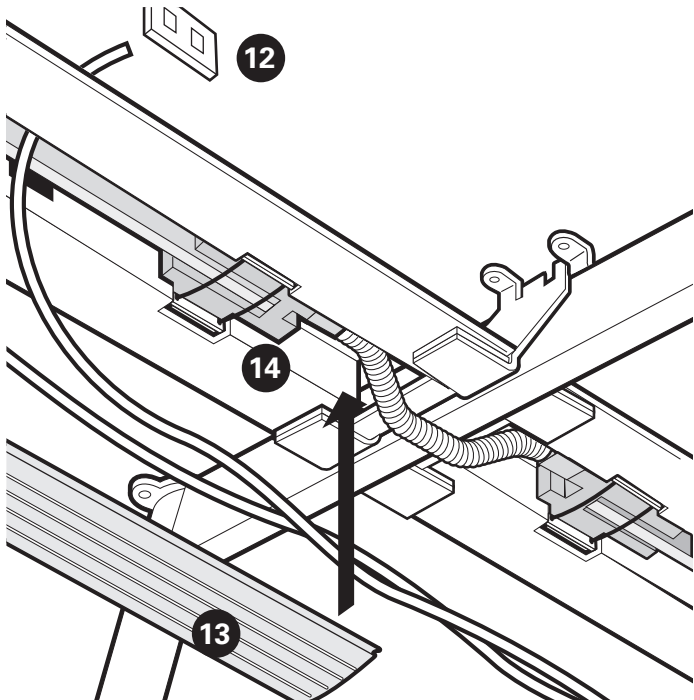
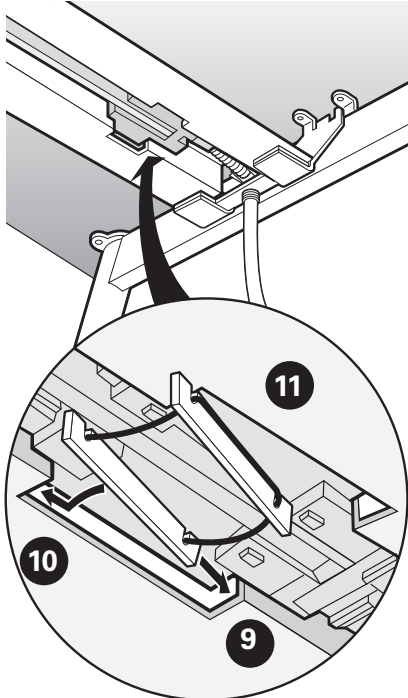

## Single Sided Power Trough

STEP 1: Identify correct length of Single- sided Power Trough and position it up against the bottom of worksurface so that its shorter lip rests against the table supporting beam.  
Center it sideways so that its center becomes aligned with the center of the worksurface.

STEP 2: Secure it to the worksurface with supplied screws.

Identify type and location of required electric components and position them on the floor in accordance with lay-out plans.

STEP 3: Install Duplex Receptacles, with circuit numbers in accordance with the electrical plans. NOTE : There is an arrow and a letter "N" on each Power Distribution Housing, Duplex receptacle and on every Jumper Harness referring to the correct position in relation to each other.

STEP 4: Connect Power Distribution Housings, Jumper Harnesses and Base feed.

STEP 5: Slide Power Distribution Housing with Duplexes, Jumpers and Base feed into the Trough. Ensure that all Duplexes are properly seated in the openings.

STEP 6: Secure with supplied 1/4-20 screw and special die-cast washer. See detail illustration. The screws lead through the gap between Power Distribution Module terminals and into two weld-nuts inside the Trough.

STEP 7: Align Base feed plate with 4 threaded inserts on the Trough and secure with four supplied #10-24 screws.

STEP 8: Thread data/communication cables through Trough terminal opening and make jack/terminal plate connections.

STEP 9: Scoop up data/communication cables into the cable manager and snap the manager into the Trough while making sure that the groove in the extruded manager is engaged with all inwardly pointing Trough tabs.

Ensure that all electrical components are interconnected and secured to Power Troughs. Connect Power Feed to the building power supply.

**NOTE: There must be only one power feed entry into each cluster of harnesses.**  
**WARNING! It is recommended that installation of the wiring system be made under the supervision of a licensed electrician in accordance with applicable codes and regulations. Connection to the building power supply must be done by a licensed electrician. Do not connect or disconnect components while the system is under load. Disconnect the main power before servicing or reconfiguration.**

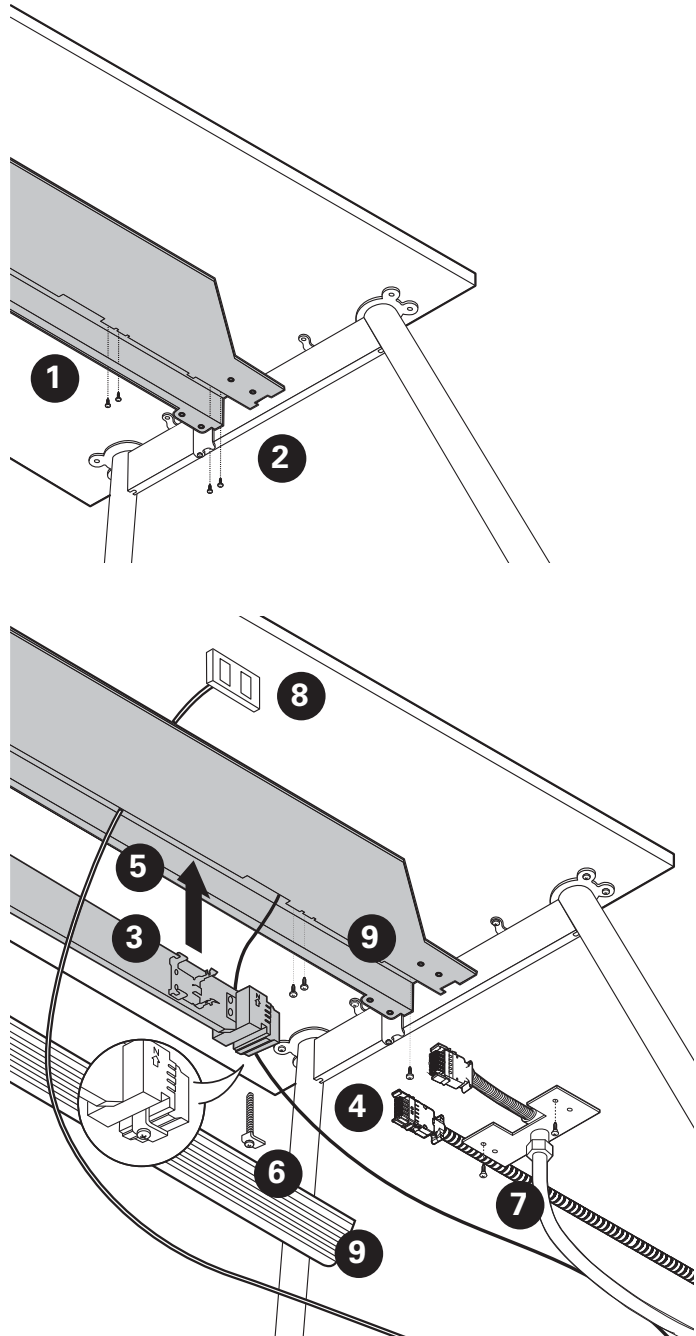

## Above Worksurface Power Trough

Identify correct length of Above Worksurface Power Troughs and place them on worksurface in their respective locations.

Identify type and location of required electric components and position them in accordance with lay-out plans.

STEP 1: Install Duplex Receptacles, with circuit numbers in accordance with the electrical plans. NOTE : There is an arrow and a letter "N" on each Power Distribution Housing, Duplex receptacle and on every Jumper Harness referring to the correct position in relation to each other.

STEP 2: Connect Power Distribution Housings and Jumper Harnesses.

STEP 3: Thread Base feed's metal conduit with connector between worksurfaces, Connect Power Feed to the Power Distribution Module (ensure that the liquid tight whip is long enough to reach the power source / floor monument). If the plans call for Ceiling feed then connect it with Power Distribution Housing and let the rest of the metal conduit rest on the worksurface for now.

STEP 4: Slide Power Distribution Housing with Duplexes, Jumpers and Power feed into the Above Worksurface Power Trough. Ensure that all Duplexes are properly seated in the openings, and secure with supplied 1/4-20 screw and special die-cast washer. See detail illustration. The screws lead through the gap between Power Distribution Module terminals and into two weld-nuts inside the Trough.

STEP 5: Slide four Duplex retainers into the Power trough openings. Lower tabs of the retainer are provided with semi - spherical protrusions which snap into holes in the Power Trough - thus keeping the Duplexes in place.

STEP 6: Slide Ceiling feed opening cover in place if you are using Base feed; leave it off if you are using Ceiling feed.

STEP 7: Install Above Worksurface Power Trough End covers at the end of a trough run. No covers are installed between two adjacent Above Worksurface Power Troughs. Secure the End covers with two supplied screws. Ensure that the covers are aligned with sheet metal case of the Trough.

STEP 8: Lower the assembly into the gap between back-to-back worksurfaces

STEP 9: Insert bracket's tab in vertical position into elongated slots in Above Worksurface Power Trough.

STEP 10: Rotate the bracket upward

STEP 11: Secure brackets with supplied screws

STEP 12: Align Power Feed's mounting plate with Above Worksurface Power Trough and secure it to worksurface with four supplied screws.

STEP 13: Thread data/communication cable past the Power Distribution Module and out through data/com opening. Make cable / terminal jacks / terminal plate connections and snap terminal plate into the Above Worksurface Power Trough.

STEP 14: Scoop up data/communication cables into the cable manager and snap the manager into the Above Worksurface Power Trough while making sure that the groove in the extruded manager is engaged with all inwardly pointing Above Worksurface Power Trough tabs.

Ensure that all electrical components are interconnected and secured to Power Troughs. Connect Power Feed to the building power supply.

**NOTE: There must be only one power feed entry into each cluster of harnesses.**  
**WARNING! It is recommended that installation of the wiring system be made under the supervision of a licensed electrician in accordance with applicable codes and regulations. Connection to the building power supply must be done by a licensed electrician. Do not connect or disconnect components while the system is under load. Disconnect the main power before servicing or reconfiguration.**

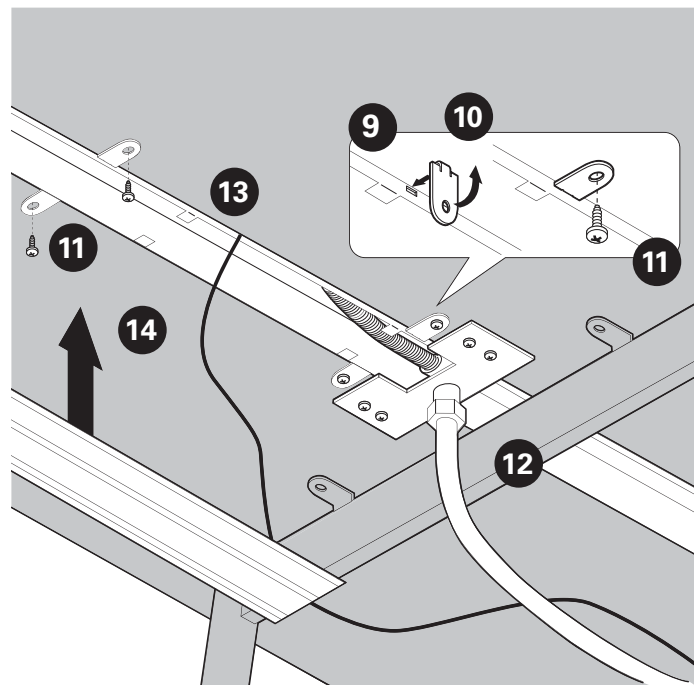
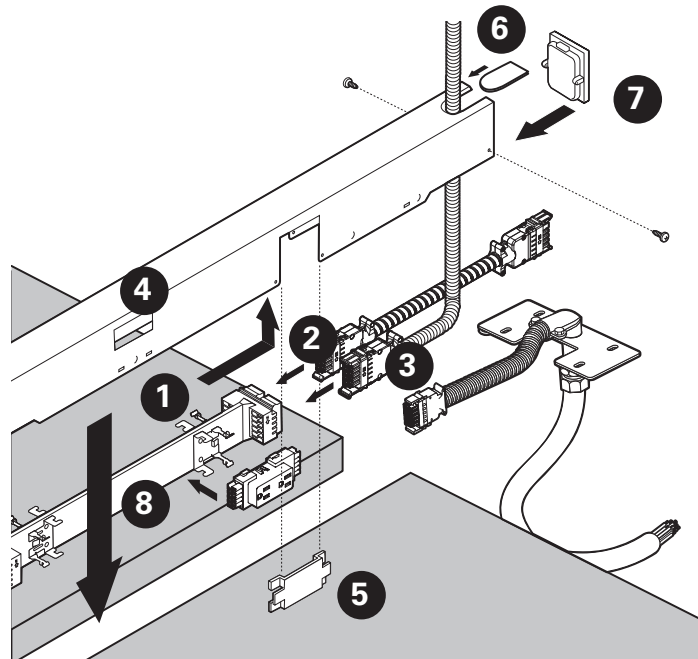

# BRIDGES II INSTALLATION GUIDE

## Back-to-Back Storage Tower Gap Filler Kit

Cover Trough's installation consists of securing four brackets to worksurfaces immediately adjacent to storage towers. Brackets can be installed in two positions, which determine whether the trough cover is going to function as an Above or Below worksurface trough cover.

### Above worksurface application.

- STEP 1: Hold bracket against storage tower corner (panels A and B).
- STEP 2: Secure four brackets by driving supplied screws into the worksurfaces, through two adjacent holes on the opposite end of the bracket as illustrated.
- STEP 3: Lower the trough cover between the storage tower. The bottom of the trough will rest on top of the bracket.

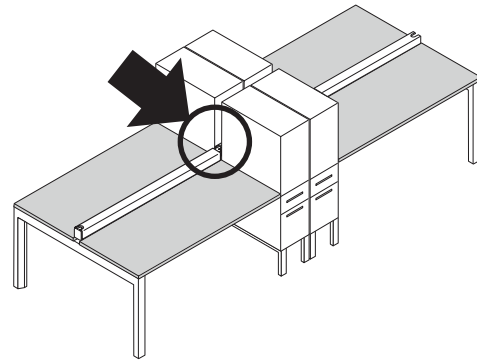

### Below worksurface application.

- STEP 4: Begin as above, by holding the bracket against the storage tower corner (panels A and B)
- STEP 5: Slide the bracket away from the tower until tip of bracket C lines up with the end of the worksurface (or storage panel B)
- STEP 6: Secure four brackets by driving supplied screws into the worksurfaces through two holes as illustrated.
- STEP 7: Lower the trough cover between the storage tower. The top of the trough will rest on the front tip of the bracket.
- STEP 8: Scoop up power and data cables and secure them to the trough with supplied rubber O ring.

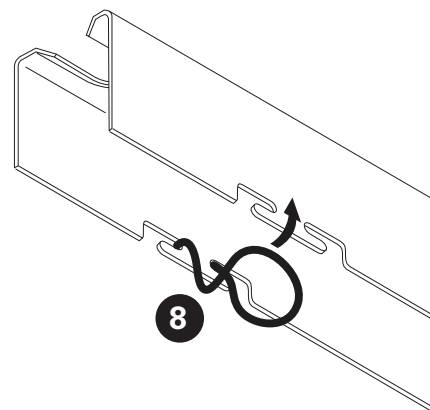
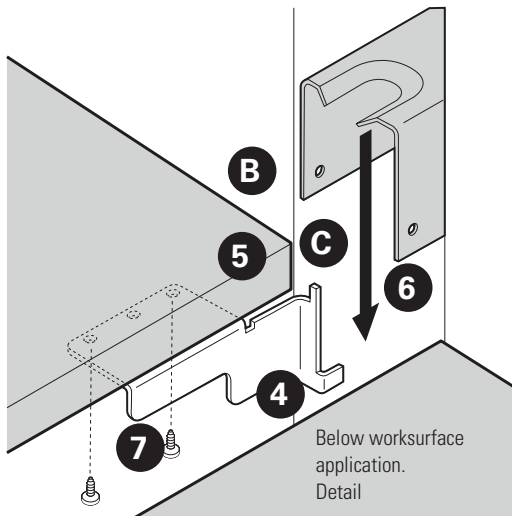
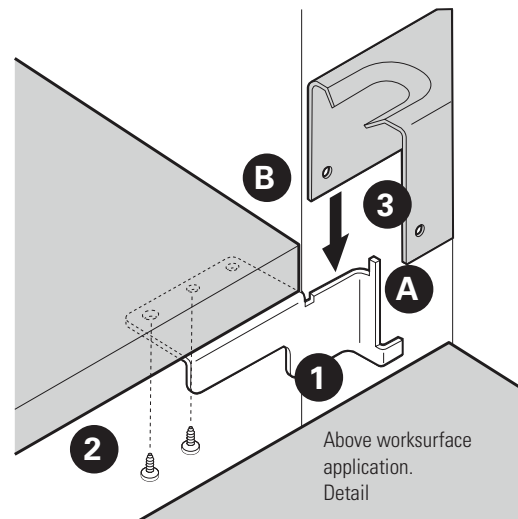

**BRTDLSHS34 Shroud**

STEP 1: Complete installation of tables, worksurfaces, power troughs, power outlets and data/communication cables.

STEP 2: Remove vertical cable manager from both legs. Engage tabs at either bottom end of the shroud with the groove in the legs (the same groove Vertical Cable Managers snap into).

STEP 3: Rotate the shroud up, into vertical position while making sure that the bottom tabs remain engaged in the leg groove.

STEP 4: Secure the shroud to worksurfaces with supplied screws (6 screws per shroud).

STEP 5: Follow the same procedure to install the second shroud on the opposite side of the leg.

STEP 6: Scoop up the data/communication cables into the cable manager and snap the manager into the power trough while making sure that the groove in the extruded manager is engaged with all inwardly pointing trough tabs.

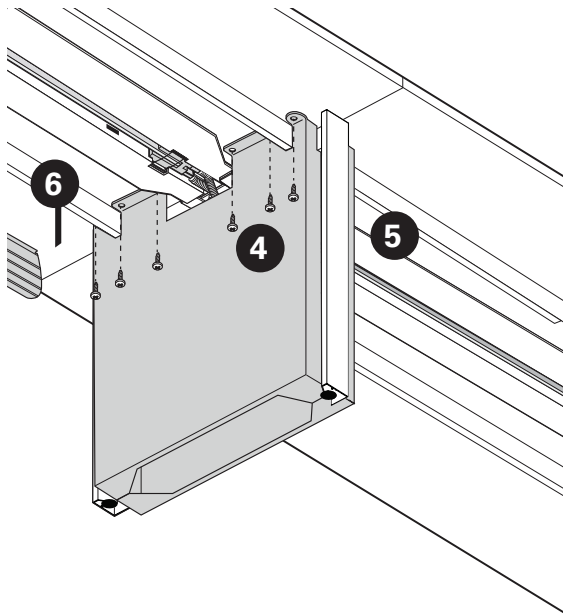
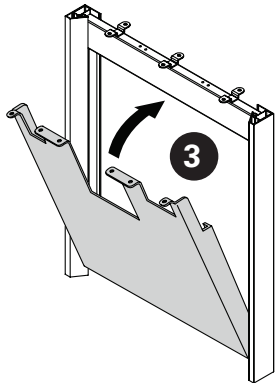
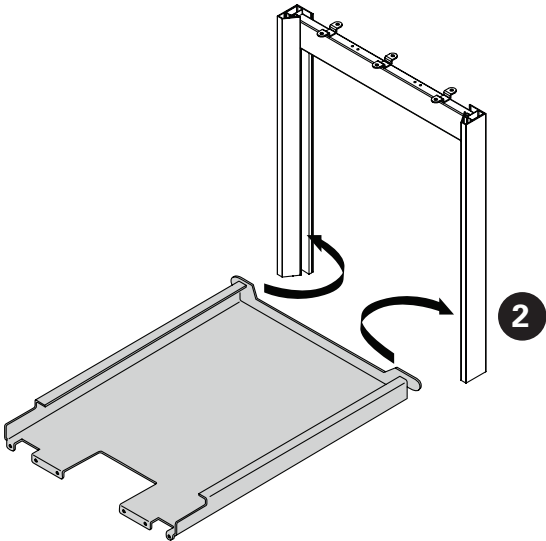
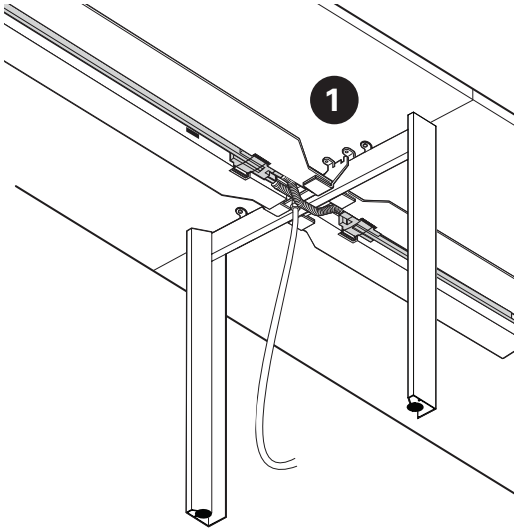

# BRIDGES II INSTALLATION GUIDE

## Ceiling Feed

Ceiling feed pole kit consists of a two-part vertical channel and two handed bottom brackets.

Ceiling feed pole installation on Above and Below Power troughs is identical. Above trough is illustrated. Ceiling feed harness has already been connected to the Power Distribution Module and data / communication cables, hanging from the ceiling, enter designated Power trough through its grommet.

STEP 1: Secure bottom brackets to the bottom of the extruded pole with four supplied screws as illustrated.

STEP 2: Organize data / communication cables and the ceiling feed metal conduit within the pole and snap the pole cover closed.

STEP 3: Insert Ceiling feed junction box bracket into the top of the channel.

STEP 4: Position the assembled pole over the Power trough.

STEP 5: Mark and cut hole in the ceiling tile. Reinstall the ceiling tile and secure top of the Ceiling feed pole to the ceiling tile grid.

STEP 6: Connect the Ceiling feed harness to the building power supply.

**NOTE: There must be only one power feed entry into each cluster of harnesses. WARNING! It is recommended that installation of the wiring system be made under the supervision of a licensed electrician in accordance with applicable codes and regulations. Connection to the building power supply must be done by a licensed electrician. Do not connect or disconnect components while the system is under load. Disconnect the main power before servicing or reconfiguration.**

STEP 7: Slide a two-part Ceiling feed bezel over the pole and secure it to the ceiling tile with supplied screws.

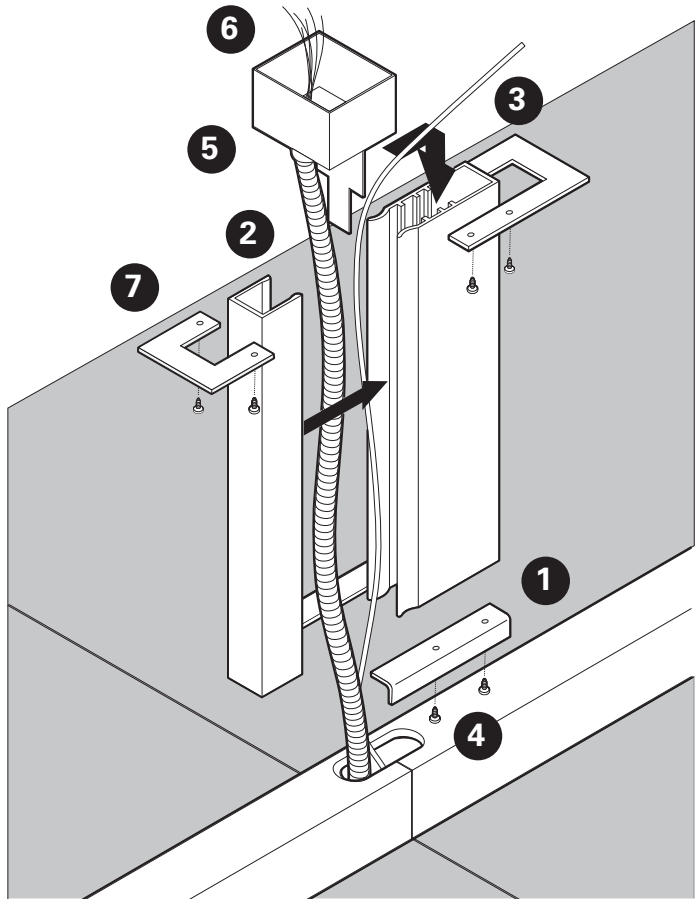

### Ceiling feed and divider application on below worksurface power trough

Specify and install divider nominally 6" shorter than the worksurface. Divider brackets remain in the same position.

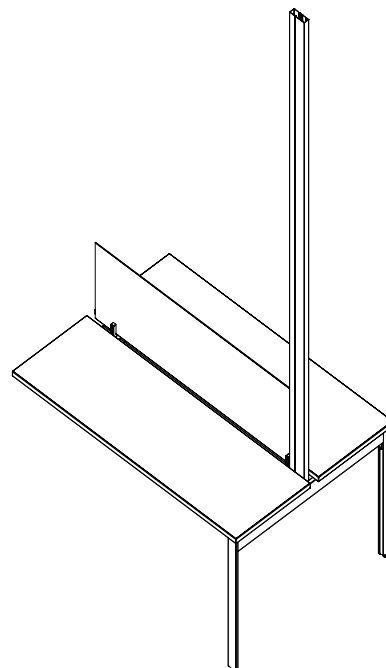

**Power Distribution Storage Power Box**

In order to secure Storage power box to Storage cabinets it is necessary to reposition one of the storage supporting legs so that it will support the Storage power box as well.

Every storage leg is provided with two hole patterns: 3+3 holes positioned closer to the edges of the leg extrusion and 2+2 hole pattern closer to the center of the extrusion.

STEP 1: Remove six screws securing the leg to the bottom of the storage unit. (3+3 hole pattern). Three of the six screws are machine thread screws. Store them in a safe place in case you will need to relocate the storage leg again in future. The remaining three long screws will be used.

STEP 2: Move the leg so that one half is located under the storage bottom, while the other half remains exposed. Align two of the 2+2 pattern holes with pre-drilled holes in the storage unit gable. Use an Allen key to secure the leg with two screws.

STEP 3: Rest the Storage power box on the leg, press it against the storage cabinet side gable. Use Allen key to secure the bottom of the Storage power box with two screws.

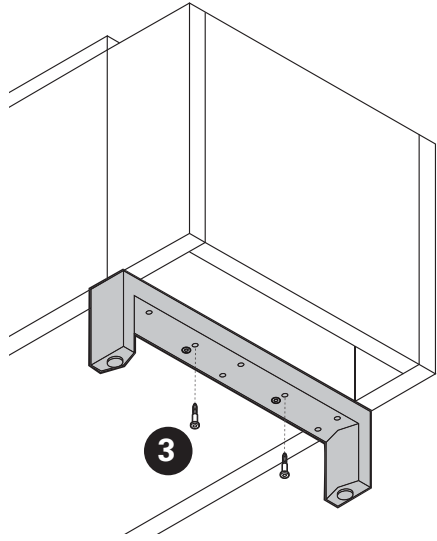
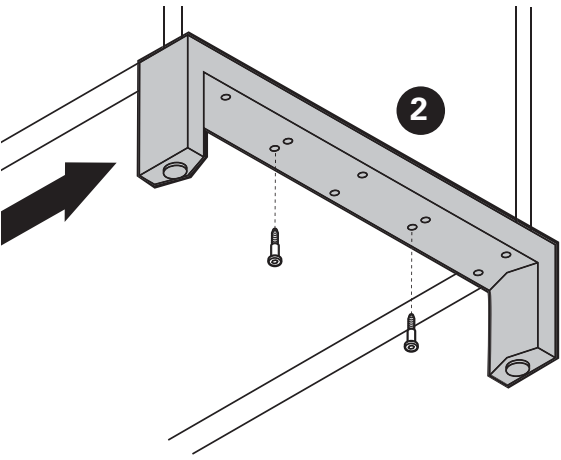
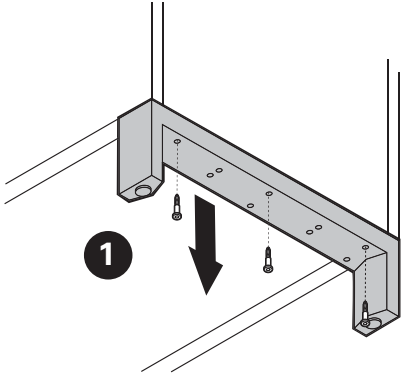

STEP 4: Lower top bracket (Left and Right brackets required) into the corner adjacent to the storage unit and rotate it so that the single-hole end of the bracket slides under storage unit top as illustrated.

STEP 5: Align the bracket with two pre-drilled holes and secure with supplied screws. Install the second bracket on the opposite side.

STEP 6: Open cabinet's door, drawer (removal of the drawer might be necessary) and secure both brackets to the storage unit's top with supplied wood screws.

STEP 7: Follow installation instructions included with the outlet/data module to secure it to the Storage Power Box top. Connect power / data cables and push the top over the box until the four connector pins snap in place.

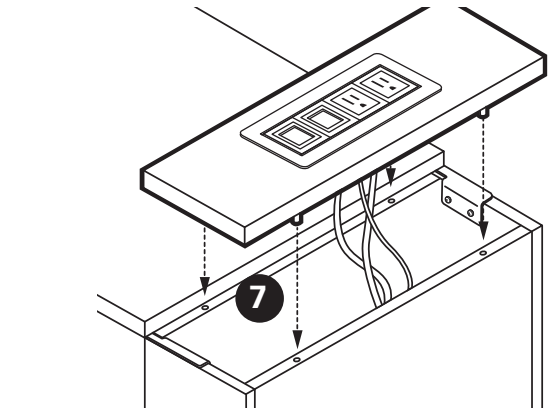
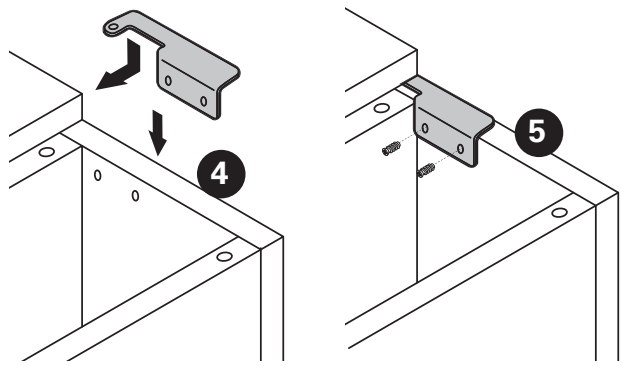

Organize cables under storage cabinets by installing Cable basket.

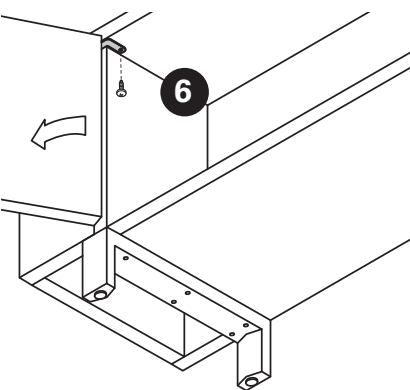

# BRIDGES II INSTALLATION GUIDE

## Parallel Dividers, Back-to-Back Tables, Glass And Laminate

36", 42", 48", 54", 60" and 72" wide dividers have two back-to-back divider brackets.  
78" and 84" dividers have three.

STEP 1: Back-to-back divider brackets can be set up to support glass dividers and laminate dividers as well.

To install **laminated** dividers insert the vertical brackets in the farthest positions A and secure them with screws C. Ensure that the screws are very tight.

To install **glass** dividers bring the vertical brackets snugly together B and secure them with screws C. Ensure that the screws are very tight.

STEP 2: Back-to-back worksurfaces are provided with pilot holes for accurate location of Back-to-back divider brackets. Align the brackets with pilot holes and secure with supplied screws.

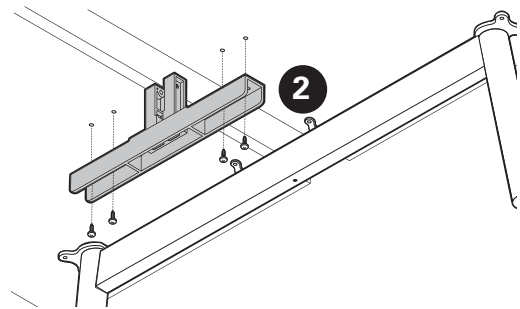
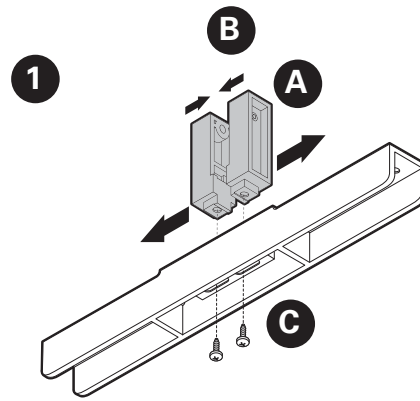

STEP 3: Insert the glass or laminate divider into the bracket while making sure that it is seated all the way at the bottom, resting on shock-absorbent pads.

STEP 4: Use Allen key to gently adjust plastic set screws while keeping the divider in vertical position. Do not over tighten!

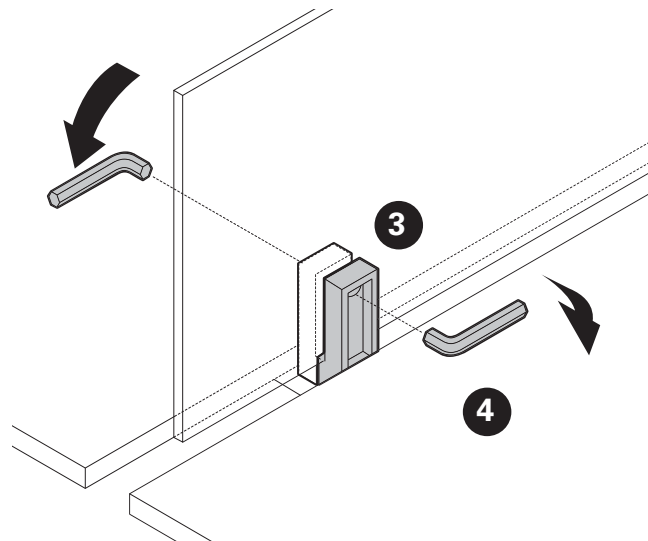



**Side-to-Side Laminate Divider**

Note: Side-2-side laminate divider can be installed in the middle of a worksurface and over two adjacent worksurfaces supported by round legs. Because rectangular legs occupy bottom corners of worksurfaces it cannot be installed over two adjacent worksurfaces unless they are supported by 34" deep Back-to-back leg.

- STEP 1: Align the front bracket with pilot holes at the bottom of Side-to-side laminate divider and secure with supplied screws.
- STEP 2: Slide the divider over the front edge of a worksurface at the desired location.
- STEP 3: Align the rear bracket with pilot holes at the rear edge of Side-to-side laminate divider and secure with supplied screws.
- STEP 4: Adjust divider's position and secure it to worksurface with supplied screws as illustrated.

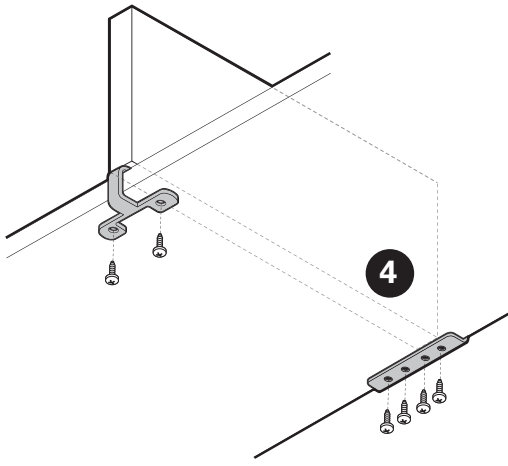
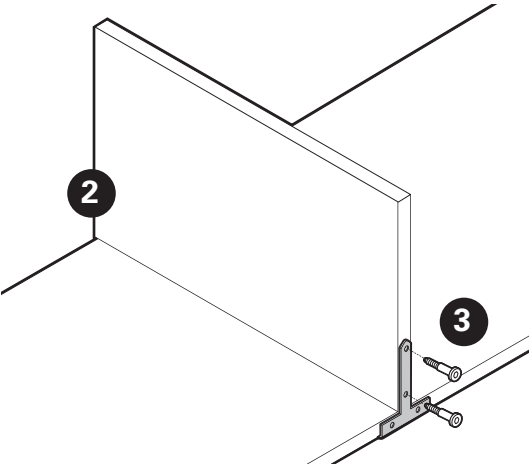
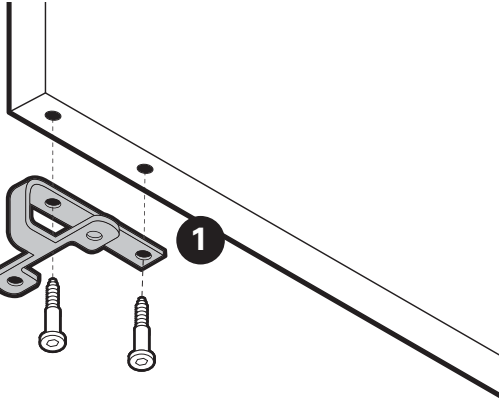

**Table Mounted Divider With Integrated Modesty Panel, Laminate**

Laminate parallel dividers are provided with 8 pilot holes.

- STEP 1: Align the brackets with pilot holes and secure with supplied screws.
- STEP 2: Have two people hold the divider with pre-installed brackets against the bottom of the table worksurface. Align the brackets with pilot holes in the worksurface as illustrated and secure with supplied screws. Drive in remaining screws.

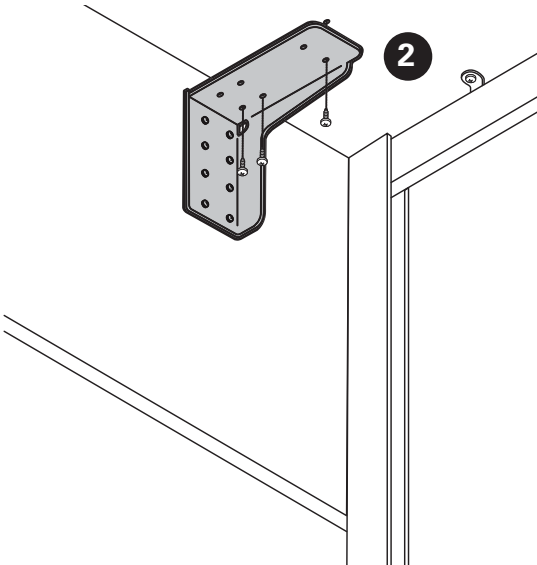
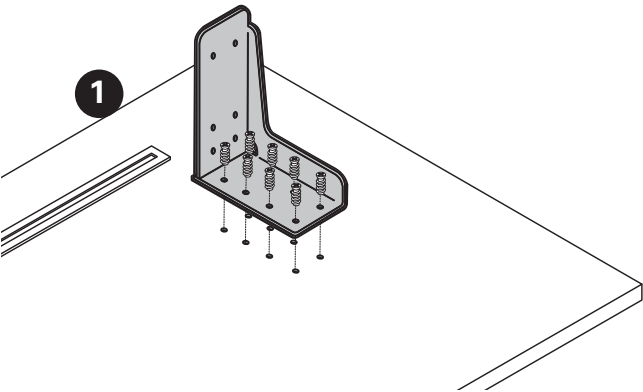
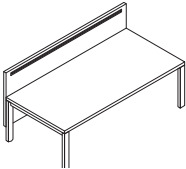

# BRIDGES II INSTALLATION GUIDE

## Perpendicular, End of Run

Note: the Perpendicular end-of-a-run divider can only be installed on rectangular legs. Remove vertical cable manager cover from both legs.

STEP 1: Align top brackets with pilot holes and secure with supplied screws.!

STEP 2: Slide the end-of-a-run divider top brackets between top of leg's horizontal beam and the bottom of the worksurface and secure with supplied screws. Note: two screws per each bracket.

STEP 3: Insert and rotate the end-of-a-run divider bottom bracket into the leg, slide it up against the bottom end-of-a-run divider edge.

STEP 4: Align the brackets with pilot holes in as illustrated and secure with supplied screws.

Trim the vertical cable manager cover and snap it back in place.

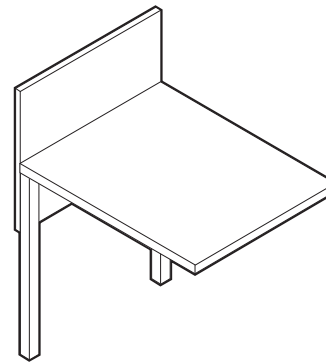
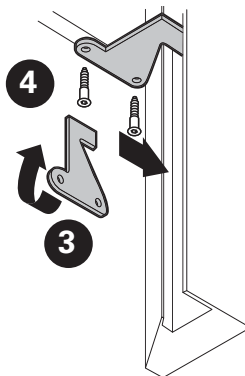
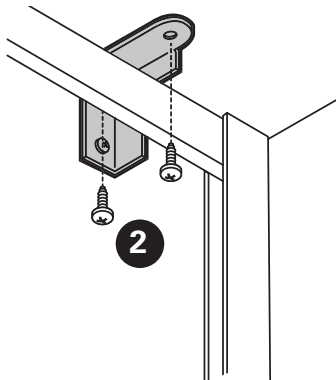
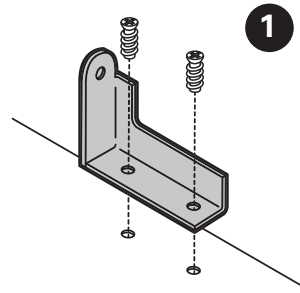

**Modesty Panel**

Recessed modesty panel flip down bracket kit consists of two pairs of brackets.

**STEP 1:** Position the small brackets on the modesty panel so that the bracket's wall with single hole **A** faces outer edge of the modesty.  
Align brackets with pilot holes and secure with supplied screws. Ensure that the two supplied shoulder screws **B** are installed in the top, smaller holes (one per each bracket).

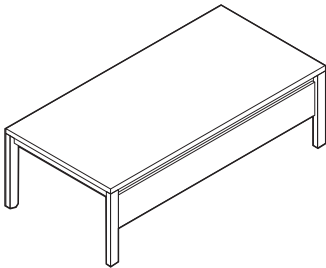

**STEP 2:** Position the large brackets against the bottom of the worksurface panel so that the bracket's wall with the oblong hole **C** faces table legs.  
Align the second hole **D** (close to the bracket's bend) with the third pilot hole **E** and secure with supplied screws. Ensure that the brackets are perpendicular to the worksurface's edge and secure the remaining screws.

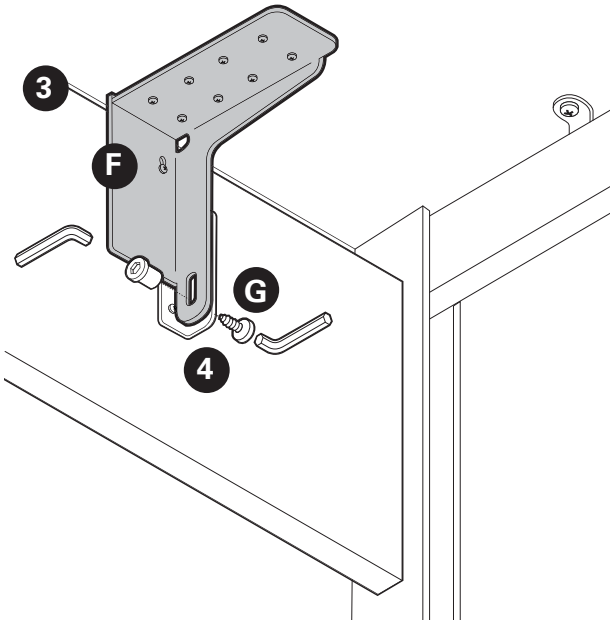
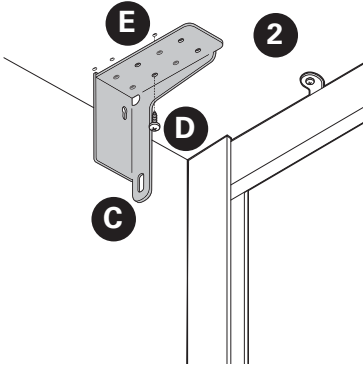
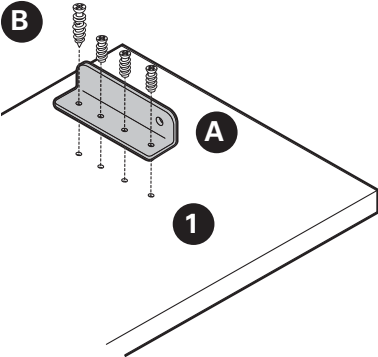

**STEP 3:** Suspend the modesty panel off the brackets by inserting both shoulder screws through the bracket's keyholes **F**.

**STEP 4:** Install joint connector screw as illustrated - the threaded stem screw **G** coming in from the leg side. Tighten with Allen keys.

**STEP 5:** Hold the center top edge of the modesty panel with one hand and the center bottom edge of the modesty panel with the other hand.  
Lift the modesty panel gently upward, making sure that both sides move up evenly. Pull the top edge gently out to disengage both shoulder screws and rotate downward.

Ensure that opening and closing action is smooth and both shoulder screws engage the keyholes easily.

# BRIDGES II INSTALLATION GUIDE

## Half Height Rectangular Leg Gable

Note: Rectangular leg gables can only be installed on rectangular legs. Proceed by removing vertical cable manager cover from both legs first.

STEP 1: Align top brackets with pilot holes and secure with supplied screws.

STEP 2: Align bottom brackets with pilot holes as illustrated and secure with supplied screws.

STEP 3: Slide the bottom brackets under the bottom of the leg extrusion.

STEP 4: Wiggle the gable slightly up while making sure that both bottom brackets are engaged with the leg extrusion.

STEP 5: Rotate into vertical position until both top brackets come between the bottom of the worksurface and the horizontal leg beam.

STEP 6: Secure the top brackets with two supplied screws while making sure that the bottom tabs remain engaged in the leg groove.

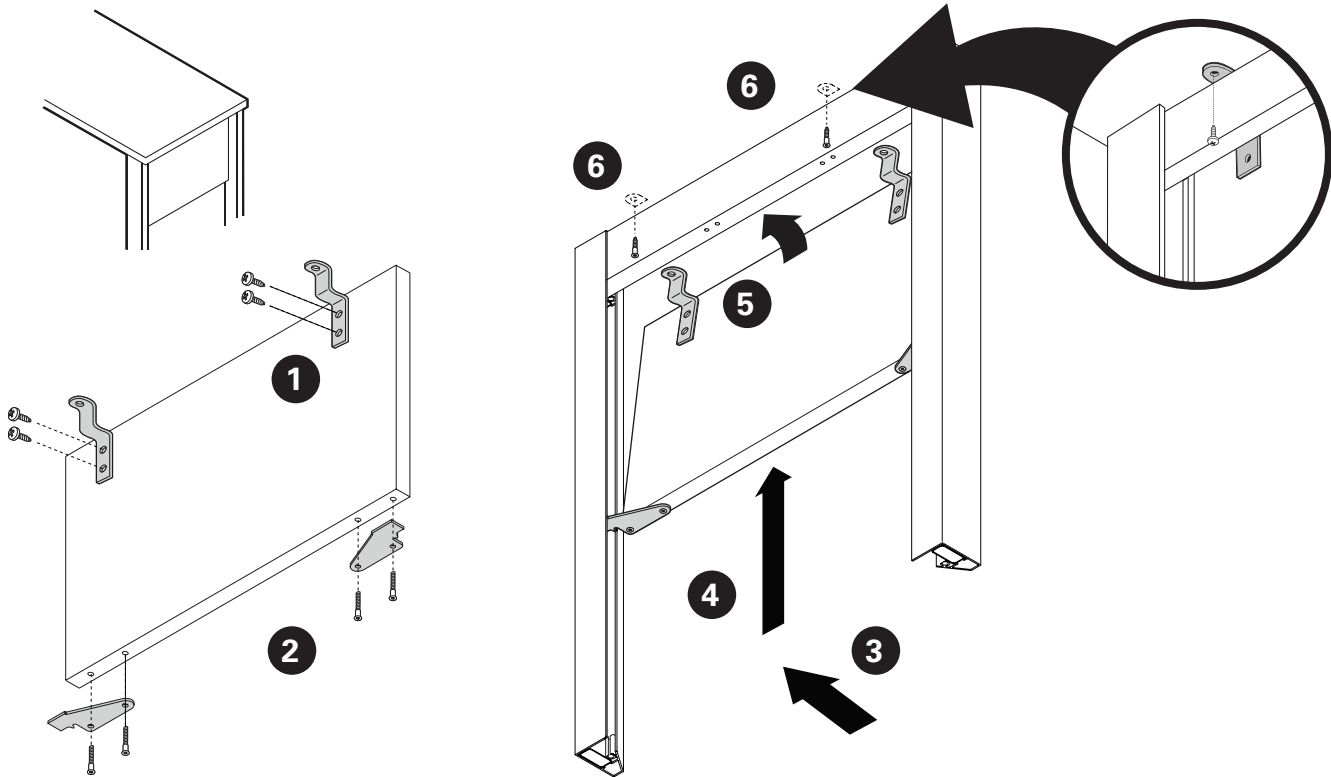

**Full Height Rectangular Leg Gable**

Note: Rectangular leg gables can only be installed on rectangular legs. Proceed by removing vertical cable manager cover from both legs first.

STEP 1: Align top brackets with pilot holes and secure with supplied screws.

STEP 2: Align bottom brackets with pilot holes as illustrated and secure with supplied screws.

STEP 3: Slide the bottom brackets under the bottom of the leg extrusion.

STEP 4: Wiggle the gable slightly up while making sure that both bottom brackets are engaged with the leg extrusion.

STEP 5: Rotate into vertical position until both top brackets come between the bottom of the worksurface and the horizontal leg beam.

STEP 6: Secure the top brackets with two supplied screws while making sure that the bottom tabs remain engaged in the leg groove.

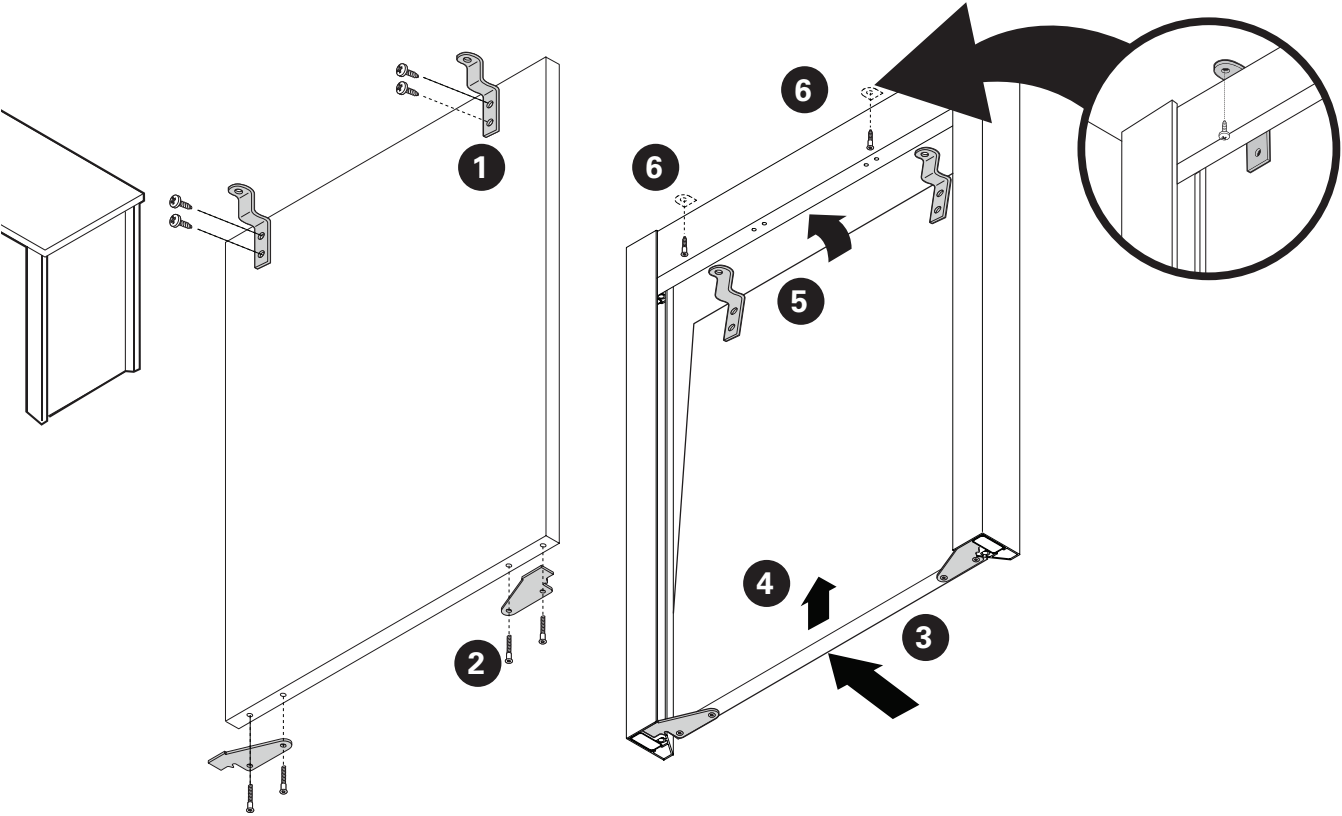

# BRIDGES II INSTALLATION GUIDE

## Table Mounted Divider with Integrated Modesty Panel, Glass

Secure Bracket to the glass.

STEP 1: Slide Rubber washer onto threaded studs.

STEP 2: Slide Spacers on the threaded studs with flange first.

STEP 3: Position bracket onto the glass and secure with two anodized caps.

STEP 4: Insert a pin into the hole in the cap and tighten.

STEP 5a: Have two installers hold the divider. Align the edges of both brackets with the back edge of the worksurface and center the brackets equidistantly between the table legs.

STEP 5b: Have two installers hold the glass modesty panel. Align the edge of the modesty panel with the inner edge of the leg. Center the modesty panel equidistantly between the table legs and secure with supplied 12 screws.

STEP 6: Secure with supplied 12 screws.

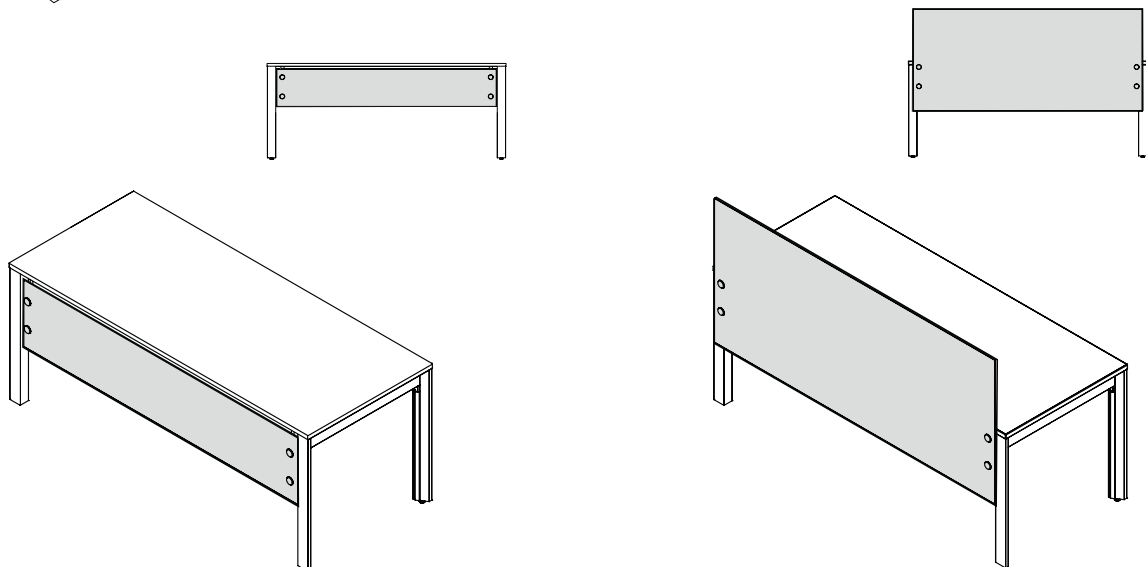
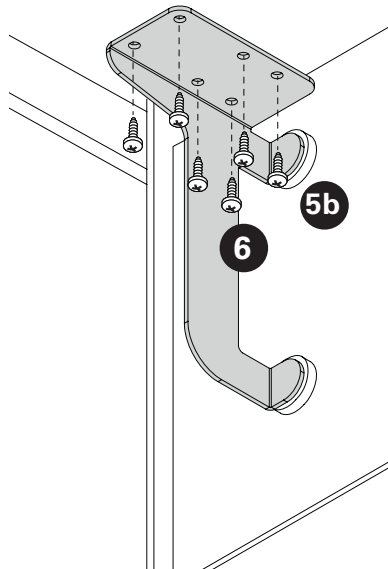
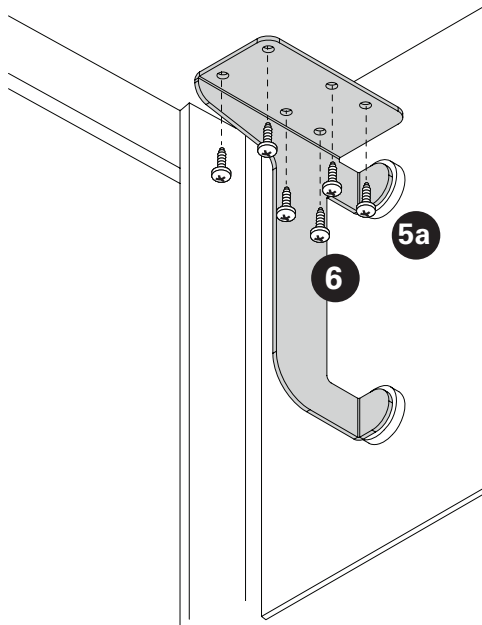
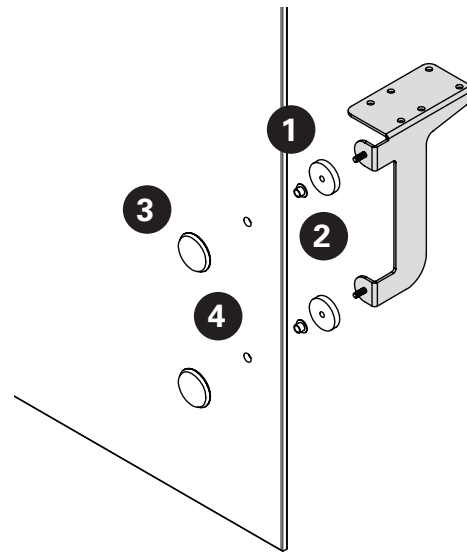

**Glass Perpendicular, End of Run Divider**

- STEP 1: Slide Rubber washer onto threaded studs.
- STEP 2: Slide Spacers on the threaded studs with flange first.
- STEP 3: Position bracket onto the glass and secure with two anodized caps.
- STEP 4: Insert a pin into the hole in the cap and tighten.
- STEP 5: Peel off the protective paper from supplied self adhesive bumpers and attach them along the bottom edge of the divider, placing the center 1/2 from dividers' vertical edge.
- NOTE: Both bumpers must be on the bracket side of the glass.
- STEP 6: Have two installers hold the divider. Align the edges of both brackets with the back edge of the worksurface and center the brackets equidistantly between the table legs.
- STEP 7: Secure with supplied 2 screws in front of and 2 screws behind the leg beam are required for the beam bracket.
- NOTE: 51" and 63" end of run glass dividers and glass modesty panels require 4 brackets.

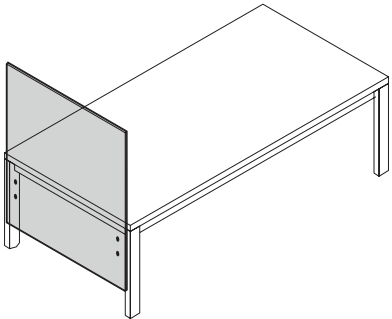
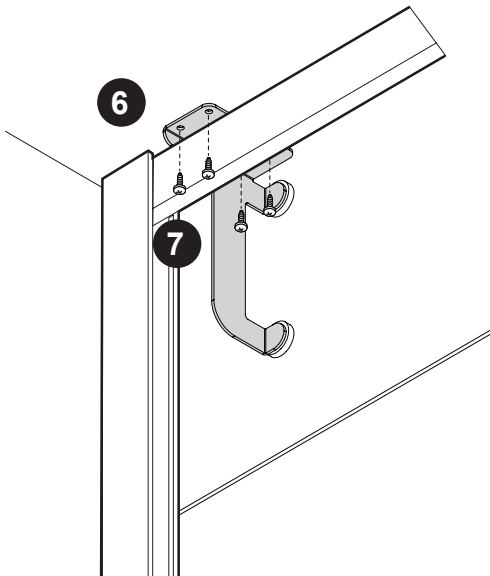
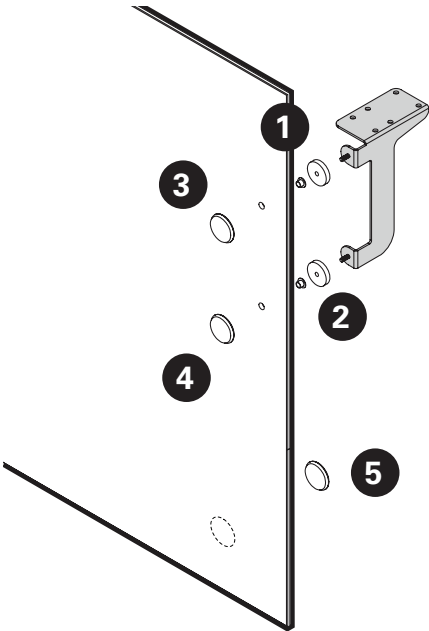

# BRIDGES II INSTALLATION GUIDE

## Perpendicular, Side-to-Side Glass Divider

STEP 1: Press the rear edge of the divider into the bracket.

STEP 2: Slide the divider with the bracket over the rear edge of the worksurface.

STEP 3: If you are installing the glass divider over a seam of two adjacent worksurfaces, press the wide bracket onto the front edge of the glass divider.

STEP 4: If you are installing the glass divider to divide one seamless worksurface or over a seam with recessed leg, then press the narrow front bracket onto the front edge of the glass divider.

STEP 5: Secure all brackets with supplied screws.

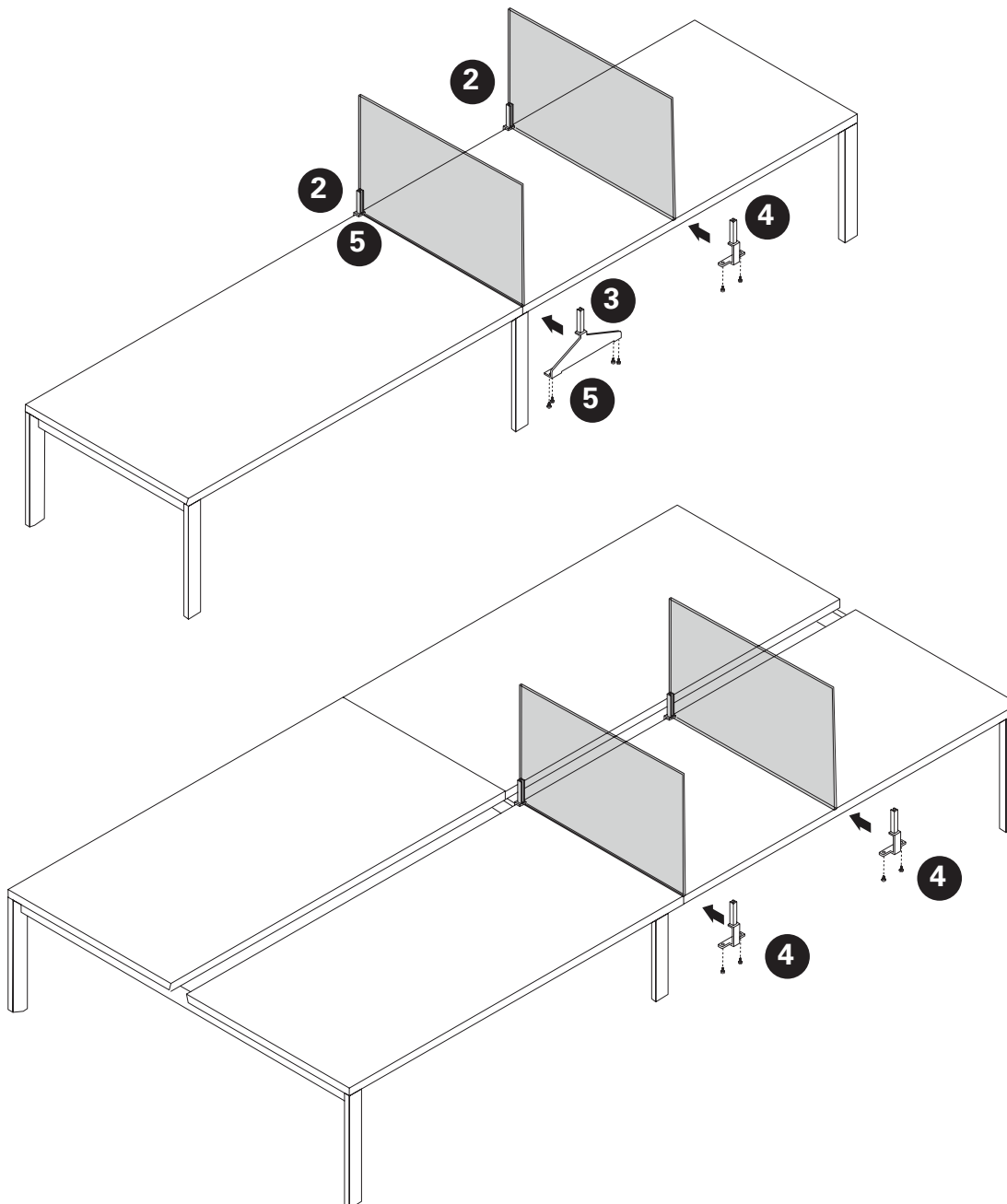
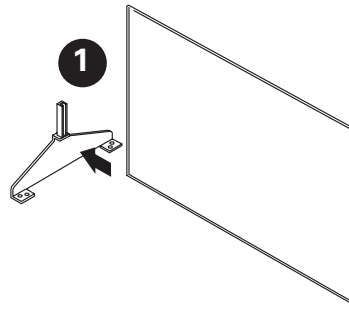



**Elevated Shelves: Parallel / Perpendicular**

Parallel elevated shelf **A** fits over gap between two back-to-back tables. Grommets in its gables accommodate cable passage and Above worksurface power trough.

Establish final location of Perpendicular elevated shelf **B** in accordance with your plans. Position it in place and peel of protective layer from adhesive tape at the bottom of the Perpendicular elevated shelf gables. Apply pressure to ensure that both shelf's gables adhered to the table's worksurfaces.

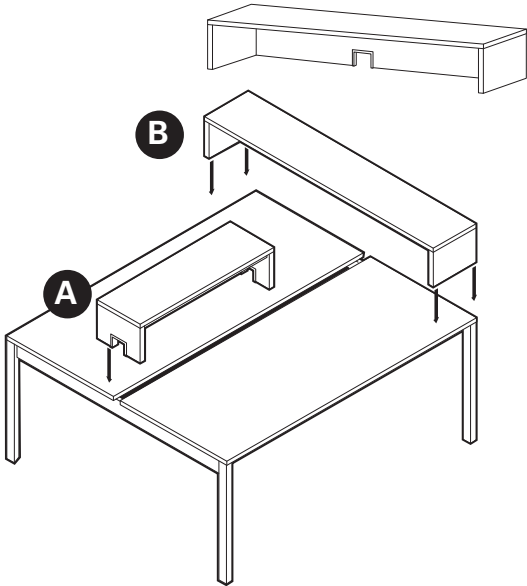

**Shared Credenza and Shared Storage Divider Placement**

Shared credenza has been designed to be placed partially under the table. Worksurface edge should be aligned with the edge of the open **A** compartment as illustrated.

Similarly, Shared storage divider's central partition edge **B** should be aligned with the worksurface as well.

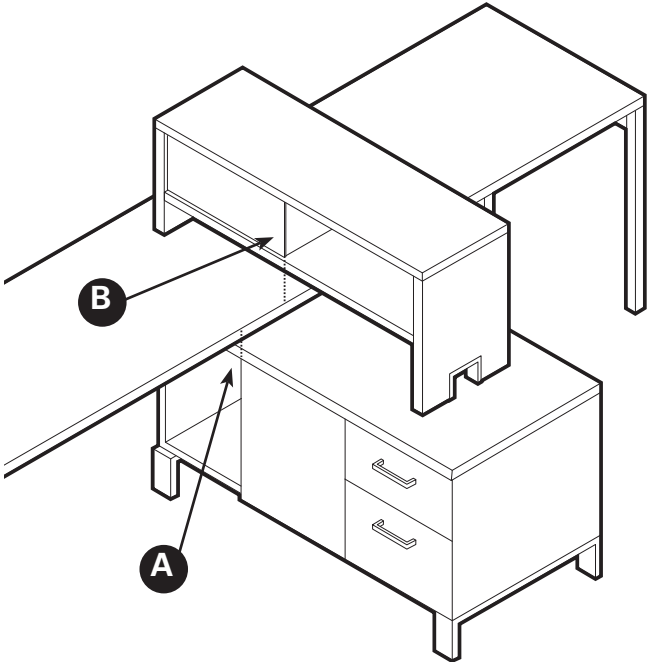

# BRIDGES II INSTALLATION GUIDE

## Table Mounted End Shelf

Note: The table end shelf can only be installed on rectangular legs. Remove vertical cable manager cover from both legs.

STEP 1: Secure hanging brackets to the table end shelf (24" and 30" table end shelves come with two, while 50.5" and 62.5" table end shelves come with four hanging brackets). Slide the brackets through back wall of the table end shelf.

STEP 2: Push the tubular part of the bracket up against the underside of the top and secure the bracket with two supplied nuts.

STEP 3: Align holes in the top part of the bracket with pilot holes and secure with supplied wood screws.

STEP 4: Hang the table end shelf onto the leg horizontal beam, ensure that all brackets are securely seated and the end shelf centered on the leg frame.

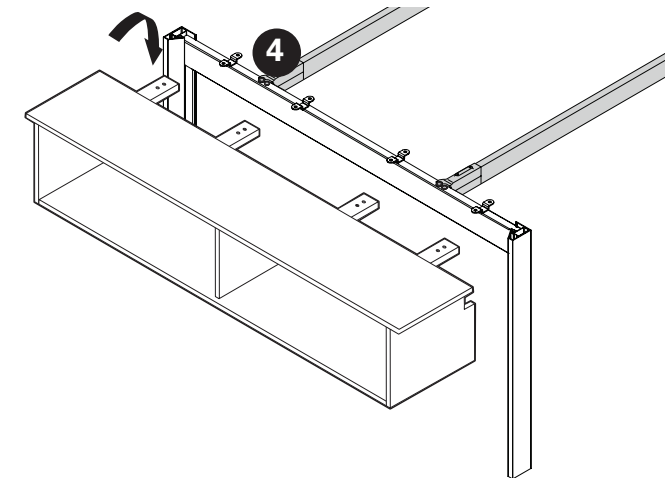
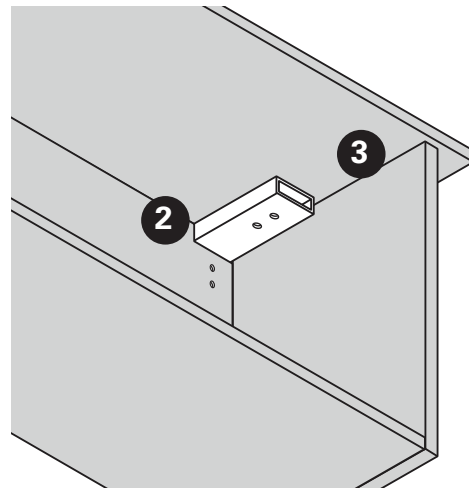
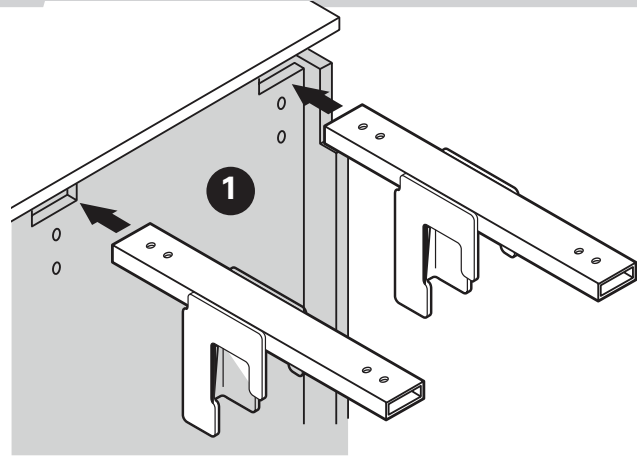

**Table Mounted End Shelf**

STEP 5: Place worksurfaces so that they line up with the external edges of the table end shelf's top. Secure worksurfaces and hanging brackets with supplied screws.

STEP 6: Insert and rotate the gable bottom bracket into the leg, slide it up against the bottom gable edge.

STEP 7: Align the brackets with pre-drilled holes in the gable as illustrated and secure with supplied screws (A).

NOTE: Use supplied machine screws (B) to secure the bracket to the threaded insert in the shelf's bottom.

Trim the vertical cable manager cover and snap it back in place.

STEP 8: Place two angled support brackets over table beams with adjustable clamps. Secure both brackets by driving supplied machine screws into threaded inserts in the back of end table shelf (A).

STEP 9: Ensure that the shelf is level.

STEP 10: Pre-tension the bracket by pushing its end along the beam and worksurface toward the shelf and, while pushing, secure the bracket by driving supplied screws into the bottom of the worksurface.

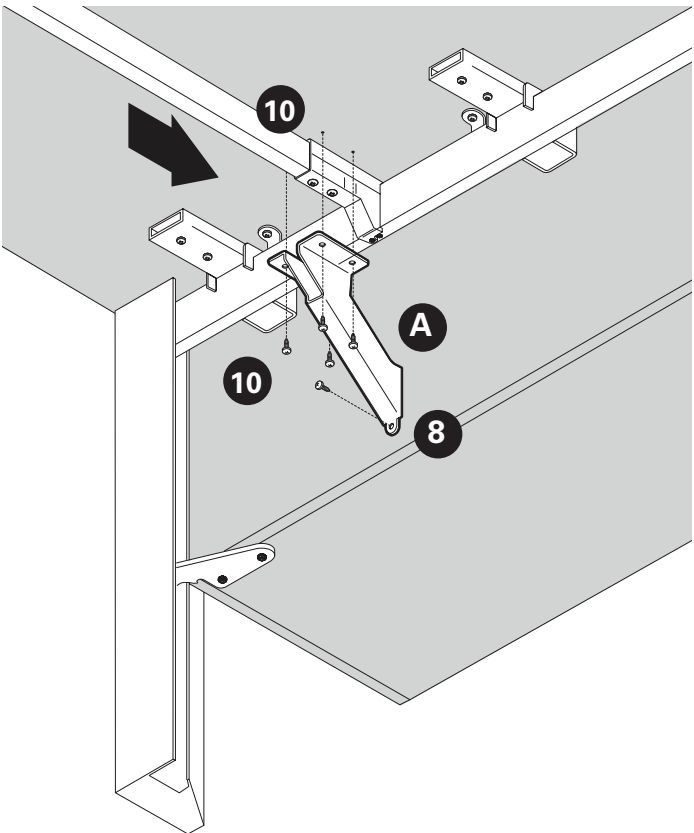
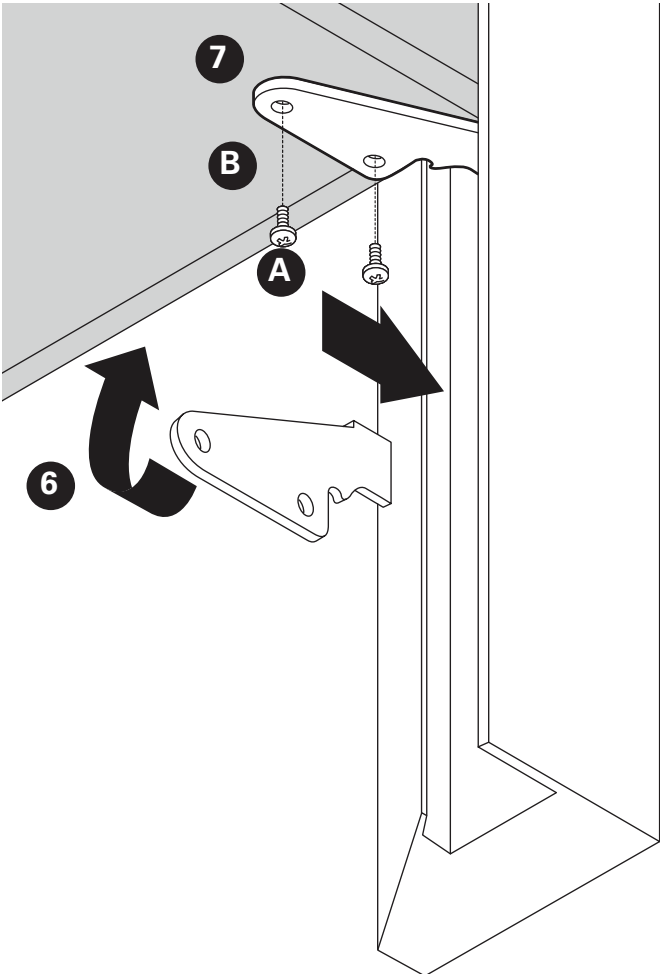
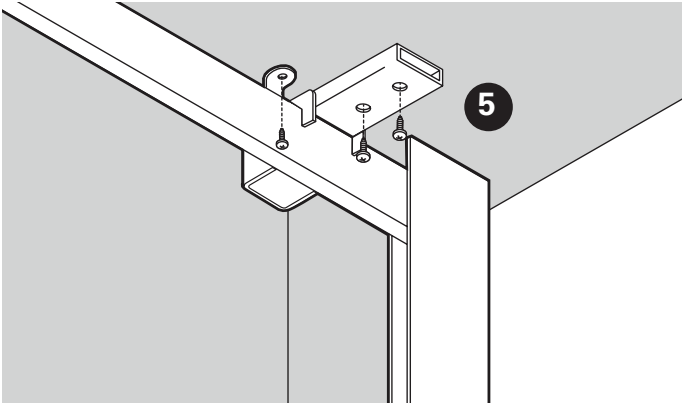

# BRIDGES II INSTALLATION GUIDE

## Storage Tower

To install storage towers in a worksurface-supporting configuration, please see support beam install.

Cable basket - Please see wire basket install under storage spine.

## Storage Spine

Storage units of equal depth can be configured to form longer, interconnected units supported by shared legs. The following steps describe how to convert a single storage leg into a shared one:

Every storage leg is provided with two hole patterns: 3+3 holes positioned closer to the edges of the leg extrusion and 2+2 hole pattern closer to the center of the extrusion.

**STEP 1:** Remove six screws securing the leg to the bottom of the storage unit. (3+3 hole pattern). Three of the six screws are machine thread screws. Store them in a safe place in case you will need to relocate the storage leg again in future. The remaining three long screws will be used.

**STEP 2:** Move the leg so that one half is located under the storage bottom, while the other half remains exposed. Align two of the 2+2 pattern holes with pre-drilled holes in the storage unit gable. Use Allen key to secure the leg with two screws.

**STEP 3:** Remove support leg from the adjacent storage unit, rest the unit on the shared leg, press it against the storage cabinet's side gable. Use Allen key to secure the bottom of the adjacent storage unit with two screws.

Keep the removed leg and fasteners in a safe place for future reconfigurations.

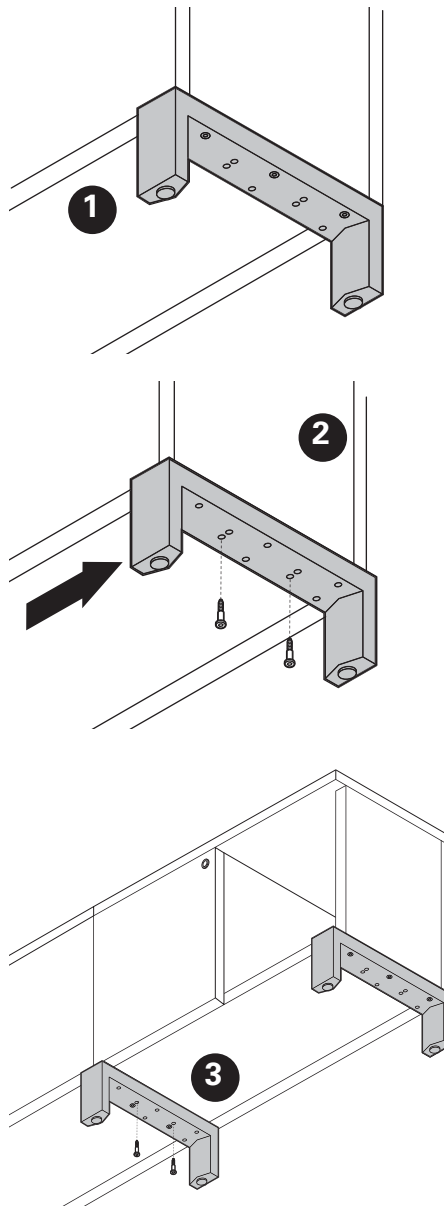

**Storage Cabinet Leg Assembly**

STEP 1: Identify Screws:

(A) 6 pcs. - 1/4 - 20 x 1" Pan Head Screws

(B) 6 pcs - 5/16 - 18 x 1.75 Hex Socket Head Screws

STEP 2: Secure Leg to the storage cabinet with the screws.

NOTE: Drive Hex socket screws into gables.

